

Cateye ergociser

CATEYE ERGOCISER

AUTOMATIC TYPE

Applicable Models: EC-1200/EC-1600/EC-3600/EC-3700

SERVICE MANUAL

INDEX

INTRODUCTION

- How to Use This Service Manual
- Name of Parts
 - 1. Upright Type (w/o Flywheel)----- 4~5
 - Upright Type (with Flywheel)----- 6~7
 - 2. Recumbent Type (EC-3600 & EC-3700) ----- 8~9
 - 3. Belt Drive (EC-1200B, EC-1600B, EC-3600B & EC-3700B) ----- ADD.1~2
- Circuit Diagram ----- 10

Part A

- Symptoms of Problems & Causes
 - T-1: No Display on Control Unit after Power ON----- 11~12
 - T-2: No Display of Cadence ----- 13
 - T-3: No Display of Pulse Rate ----- 14
 - T-4: No Printer Operation ----- 15
 - T-5: No Loading ----- 16~17
 - T-6: No Pedal Rotation (Locked) ----- 18
 - T-7: Unusual Noise
 - 1. Continuous and Increasing. ----- 19
 - 2. Periodical. ----- 20
 - 3. Noise occurs when the pedal is rotated with a large loading. ----- 21

Part B

- Removing the Frame Covers
 - D-1: Upright Type (EC-1200 & EC-1600)----- 22
 - D-2: Recumbent Type (EC-3600 & EC-3700) ----- 23

● **Repair & Adjustment Methods**

	EC-1200	EC-1600	EC-3600	EC-3700		
	○	○	○	○	ES-1:	Replacing the Wiring within the Frame ----- 24
	○	○	○	○	ES-2:	Replacing the 5P Cable ----- 25~26
	○	○	○	○	ES-3:	Replacing the Power Supply Board ----- 27
	○	○	○	○	ES-4:	Correcting the Position of Solenoid Coil ----- 28
	○	○	○	○	ES-5:	Replacing the CDC Sensor ----- 29
	-	○	-	○	ES-6:	Replacing the Panel Keyboard ----- 30
	○	-	○	-	ES-7:	Replacing the Button Panel ----- 31
	○	-	○	-	ES-8:	Replacing the Printer ----- 32
	○	-	○	-	ES-9:	Adjusting the Printing Darkness ----- 33
	○	-	○	-	ES-10:	Paper Jamming in Printer ----- 24
	△G	○	○	○	MS-1:	Replacing the Workload Unit (w/o Flywheel) ----- 35~37
	○	-	○	-	MS-2:	Replacing the Workload Unit (w/ Flywheel) ----- 38
	○	-	○	-	MS-3:	Adjusting the Flywheel ----- 39
	○	○	○	○	MS-4:	Replacing the Chain ----- 40
	○	○	○	○	MS-5:	Replacing the Free Wheel Set ----- 41
	○	○	○	○	MS-6:	Replacing the Derailleur Set ----- 42
	○	○	○	○	MS-7:	Replacing the Idler Set ----- 43
	○	○	○	○	MS-8:	Replacing the Crank Set ----- 44~45
	○	○	○	○	MS-9:	Replacing the BB Set ----- 46
	○	-	○	-	MS-10:	Replacing the Post Spacer ----- 47
	○	-	○	-	MS-11:	Adjusting the Spacer Spring ----- 48
	○	-	○	-	MS-12:	Replacing the Inner Pipe Spacer ----- 49
	○	-	○	-	MS-13:	Replacing the Vertical Pipe Spacer ----- 50
	○	-	○	-	MS-14:	Replacing the Leg Cover ----- 51
	○	-	○	-	MS-15:	Replacing the Caster/Level Adjuster ----- 52
	○	-	○	-	MS-16:	Replacing the Seat Post Knob ----- 53
	○	-	○	-	MS-17:	Replacing the Lock Pin ----- 54
	○	○	○	○	MS-18:	Replacing the Crank Cover ----- 55
	○	-	○	-	MS-19:	Replacing the Center Cover of Upright Type ----- 56
	○	-	○	-	MS-20:	Replacing the Center Cover of Recumbent Type ----- 57
	○	○	○	○	MS-21:	Replacing the Handlebar Grip ----- 58
	○	-	○	-	MS-22:	Replacing the Printer Cover ----- 59
	○	-	○	-	MS-23:	Replacing the Paper Cutter ----- 60

PART C

- List of Genuine Parts ----- 61~65

How to Use This Service Manual

The manual consists of Part A, Part B and Part C. Part A refers to trouble-shooting which allows you to identify the cause and areas to be fixed depending on typical symptoms. Part B shows how to repair and/or adjust specific defects. This part consists of repair methods for electrical parts [ES] and those for mechanical parts [MS].

Part C lists up all genuine parts and corresponding part numbers that will be necessary for replacement or stock

Whenever any problem has occurred on the main unit, take the following actions to repair or adjust it.

1. Check and identify the cause by referring to Part A.
2. Identify the parts name by referring to Name of Parts.
3. Perform repair or adjustment in accordance with the instructions in Part B.
4. Replacement, if required, should be done by using genuine parts as specified in Part C.



Name of Parts for Upright Type (w/o Flywheel)

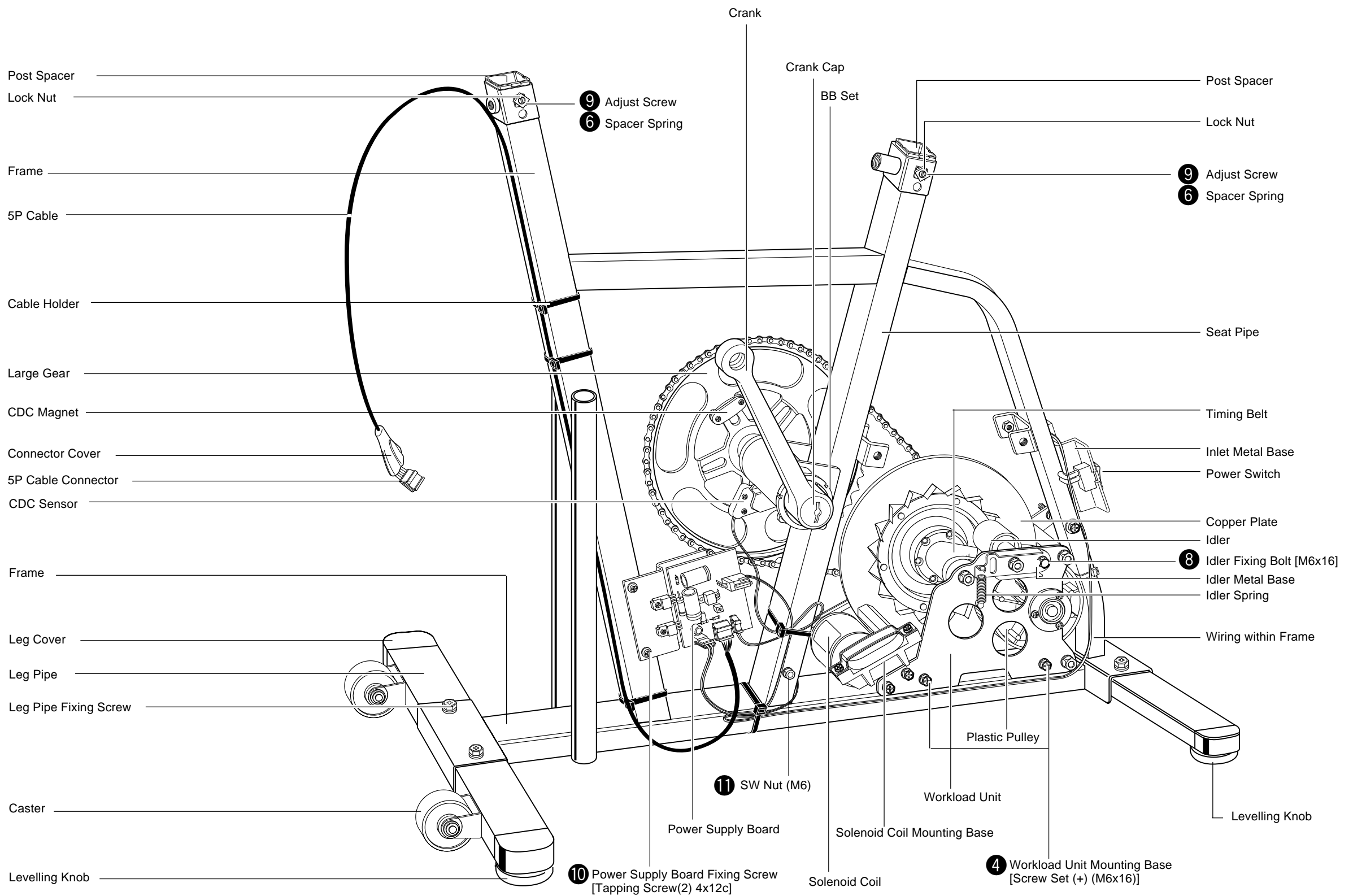

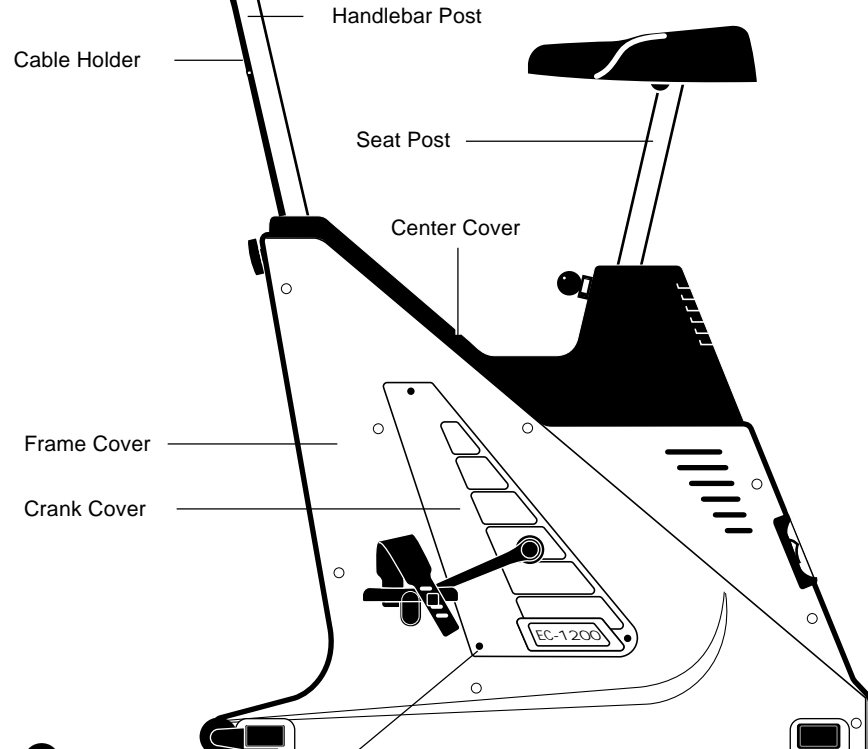
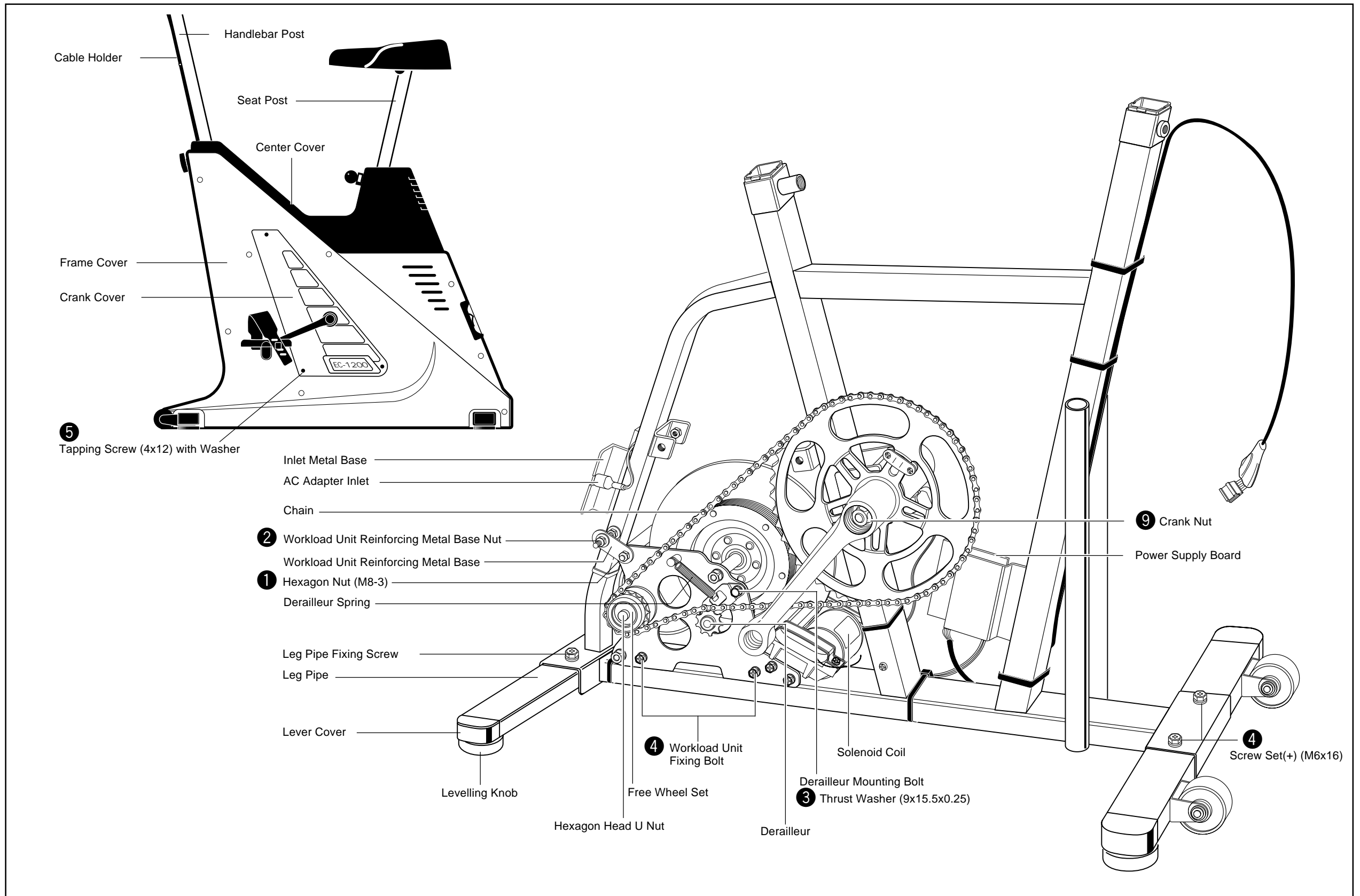

5 Tapping Screw (4x12) with Washer

- 2 Workload Unit Reinforcing Metal Base Nut
- Workload Unit Reinforcing Metal Base
- 1 Hexagon Nut (M8-3)
- Derailleur Spring

- Leg Pipe Fixing Screw
- Leg Pipe

- Lever Cover

Levelling Knob

Hexagon Head U Nut

4 Workload Unit Fixing Bolt

Free Wheel Set

Derailleur

Derailleur Mounting Bolt

3 Thrust Washer (9x15.5x0.25)

Solenoid Coil

9 Crank Nut

Power Supply Board

4 Screw Set(+) (M6x16)

Name of Parts for Upright Type (w/o Flywheel)

Name of Parts for Upright Type (w/ Flywheel)

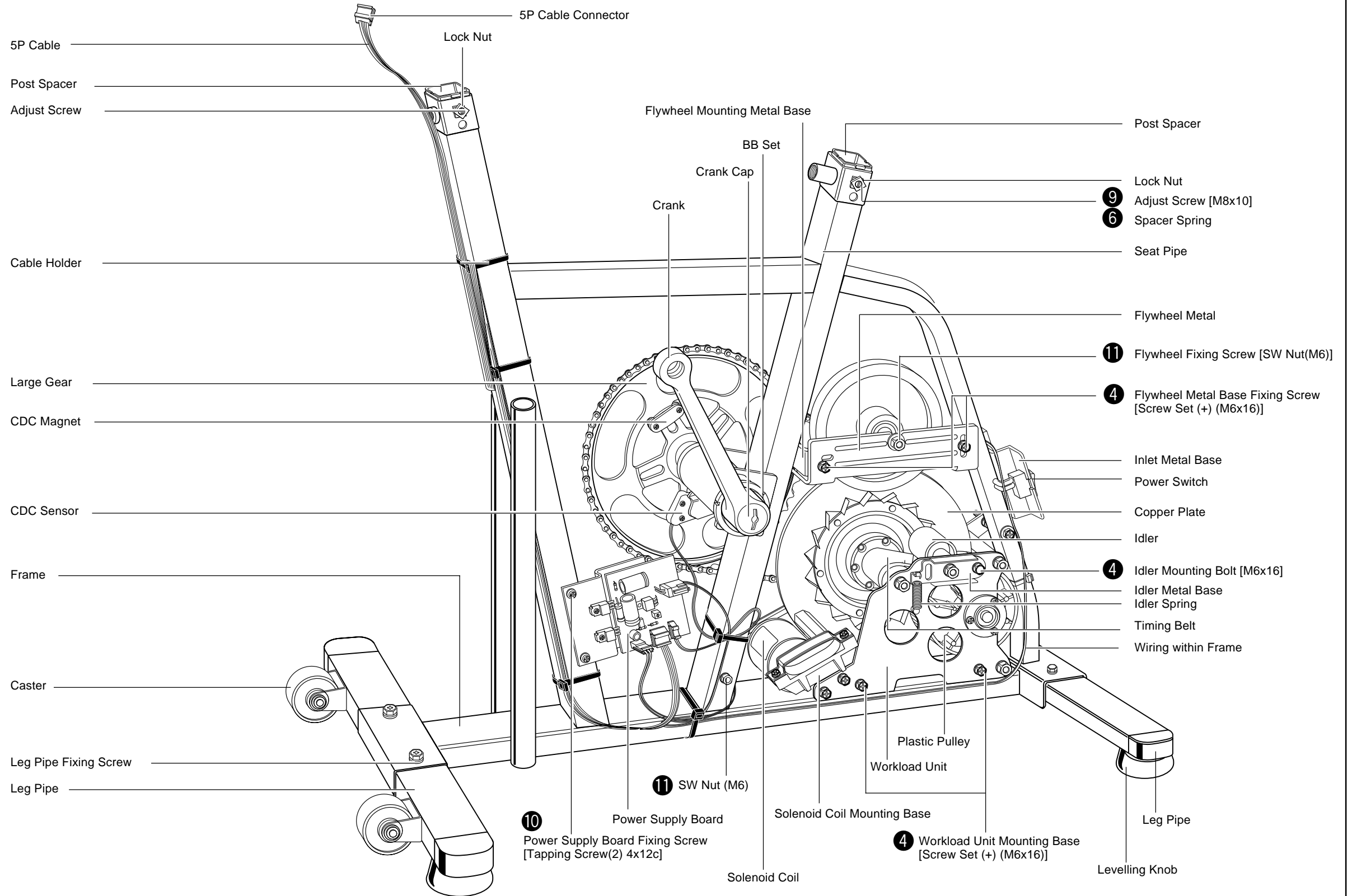

Name of Parts for Upright Type (w/ Flywheel)

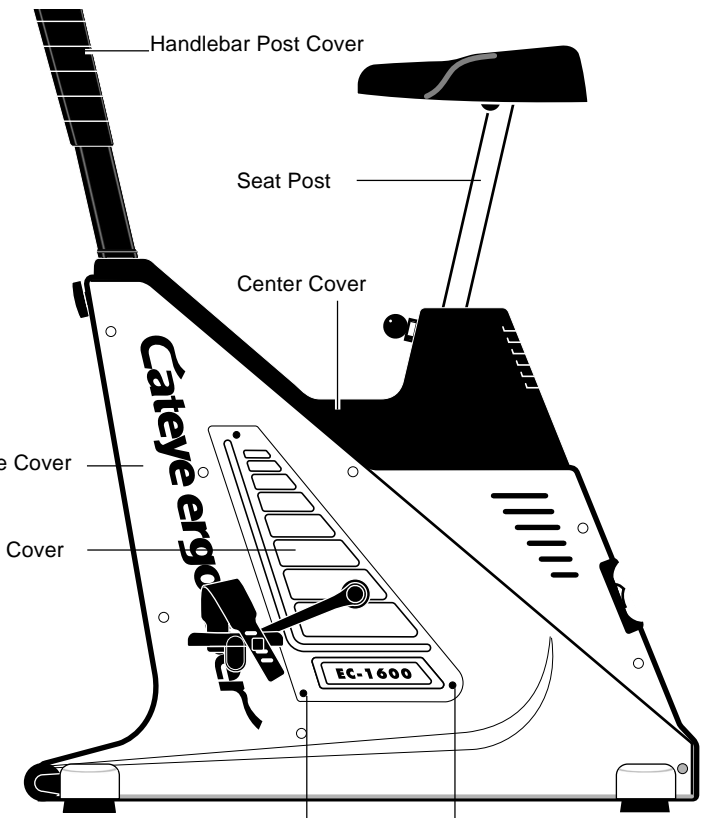
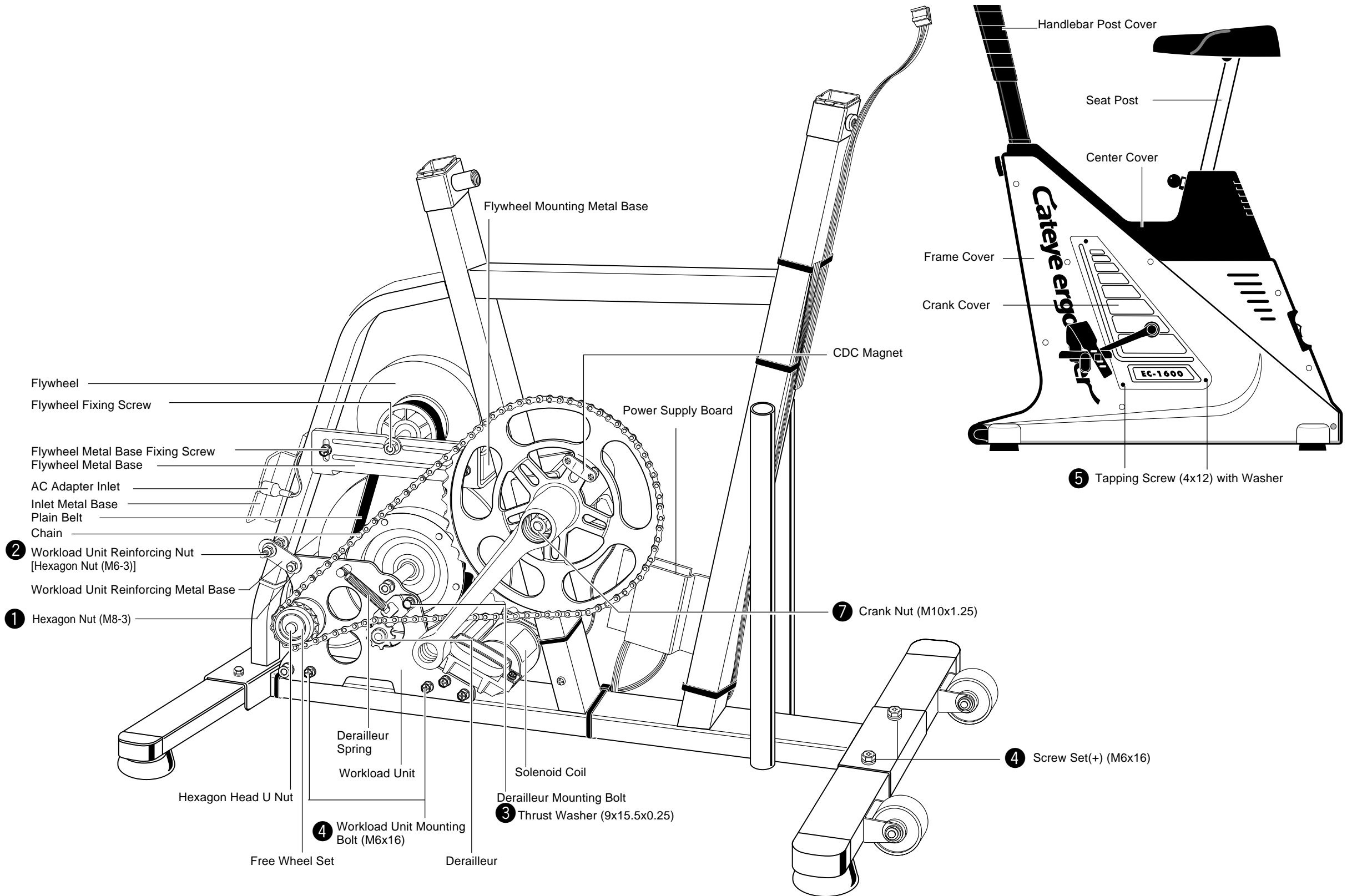

Name of Parts for Upright Type (w/ Flywheel)

Name of Parts for Recumbent Type (EC-3600 & EC3700)

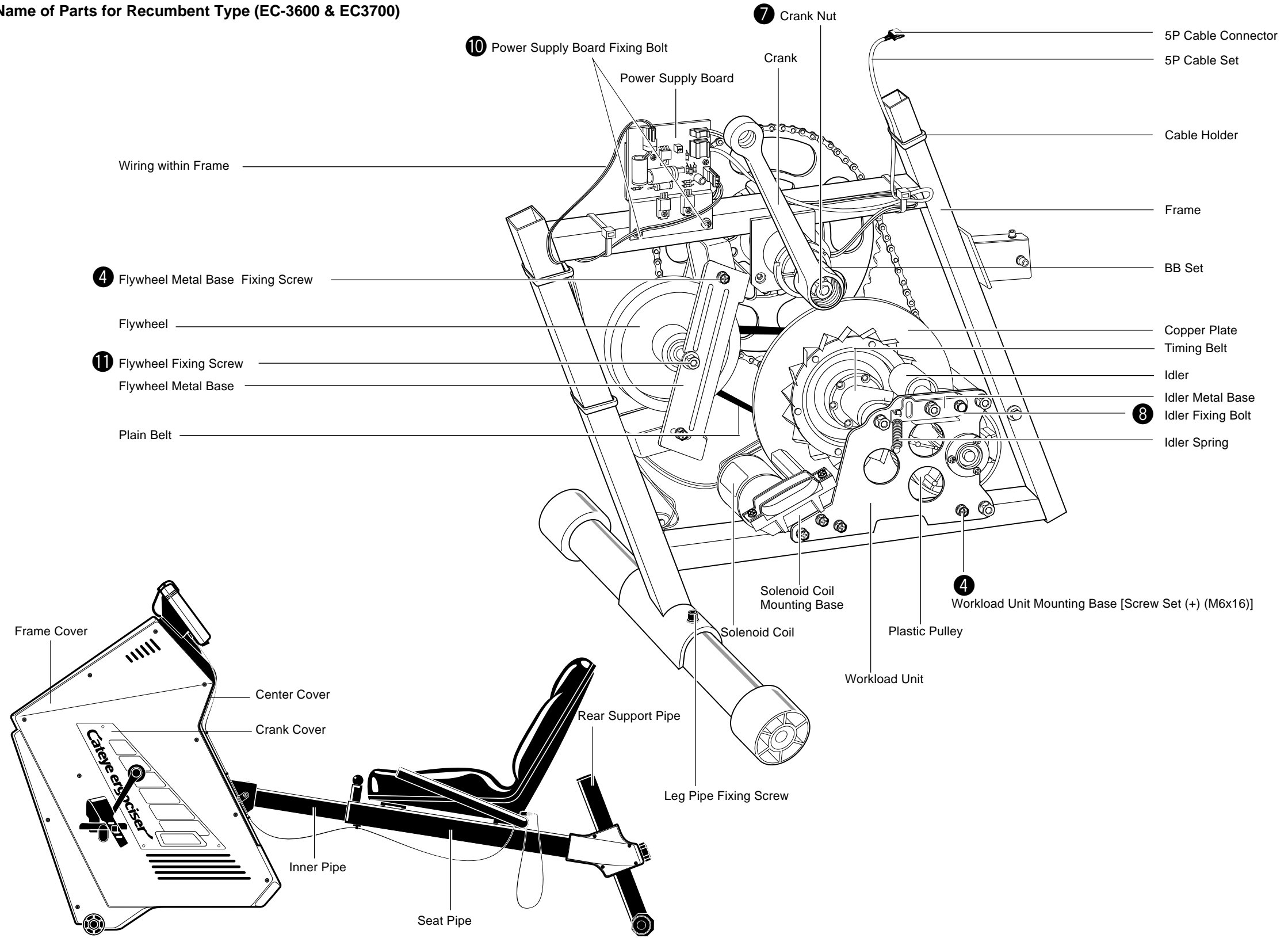

Name of Parts for Recumbent Type

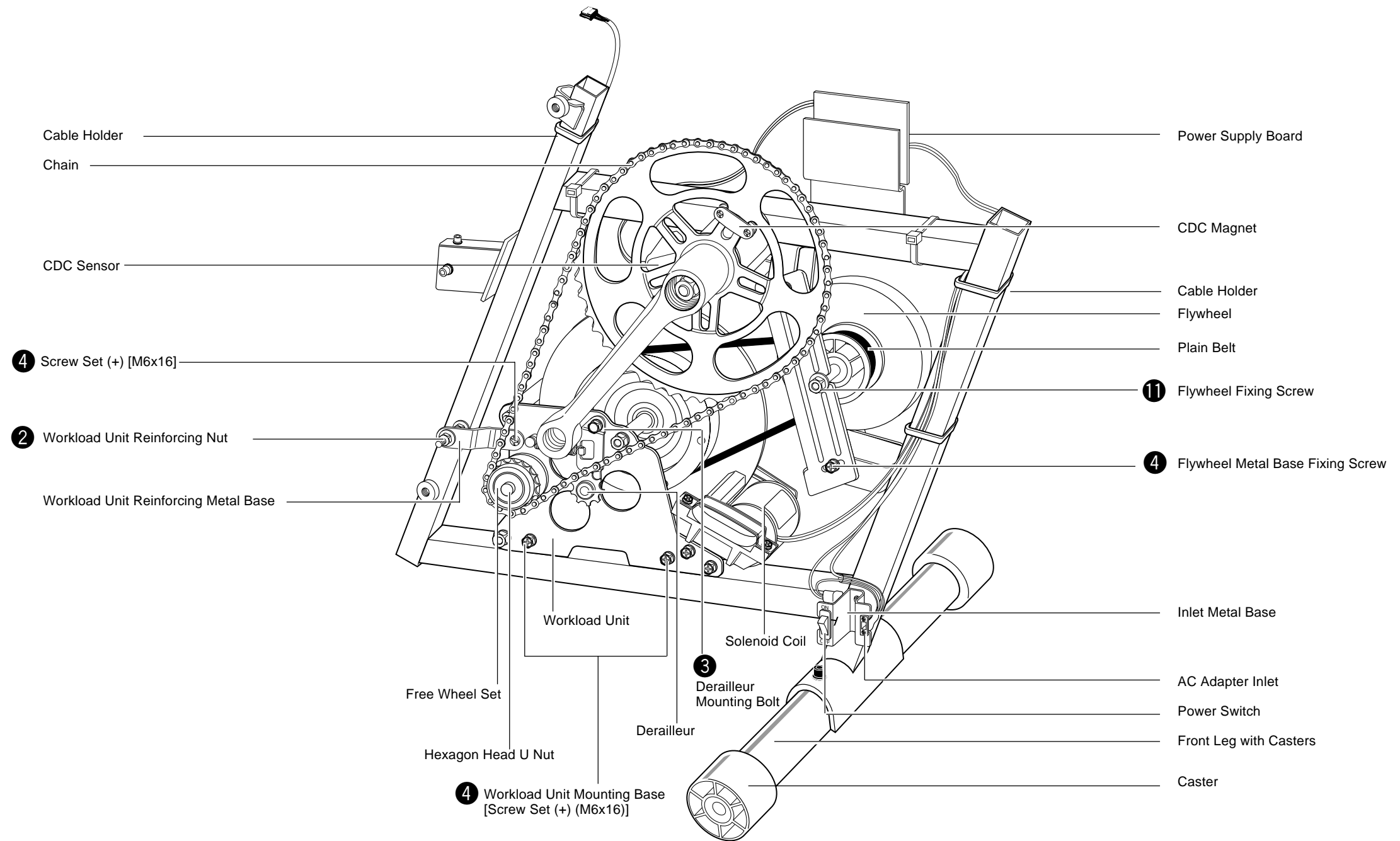

Name of Parts for Recumbent Type

Belt Drive

EC-1600B

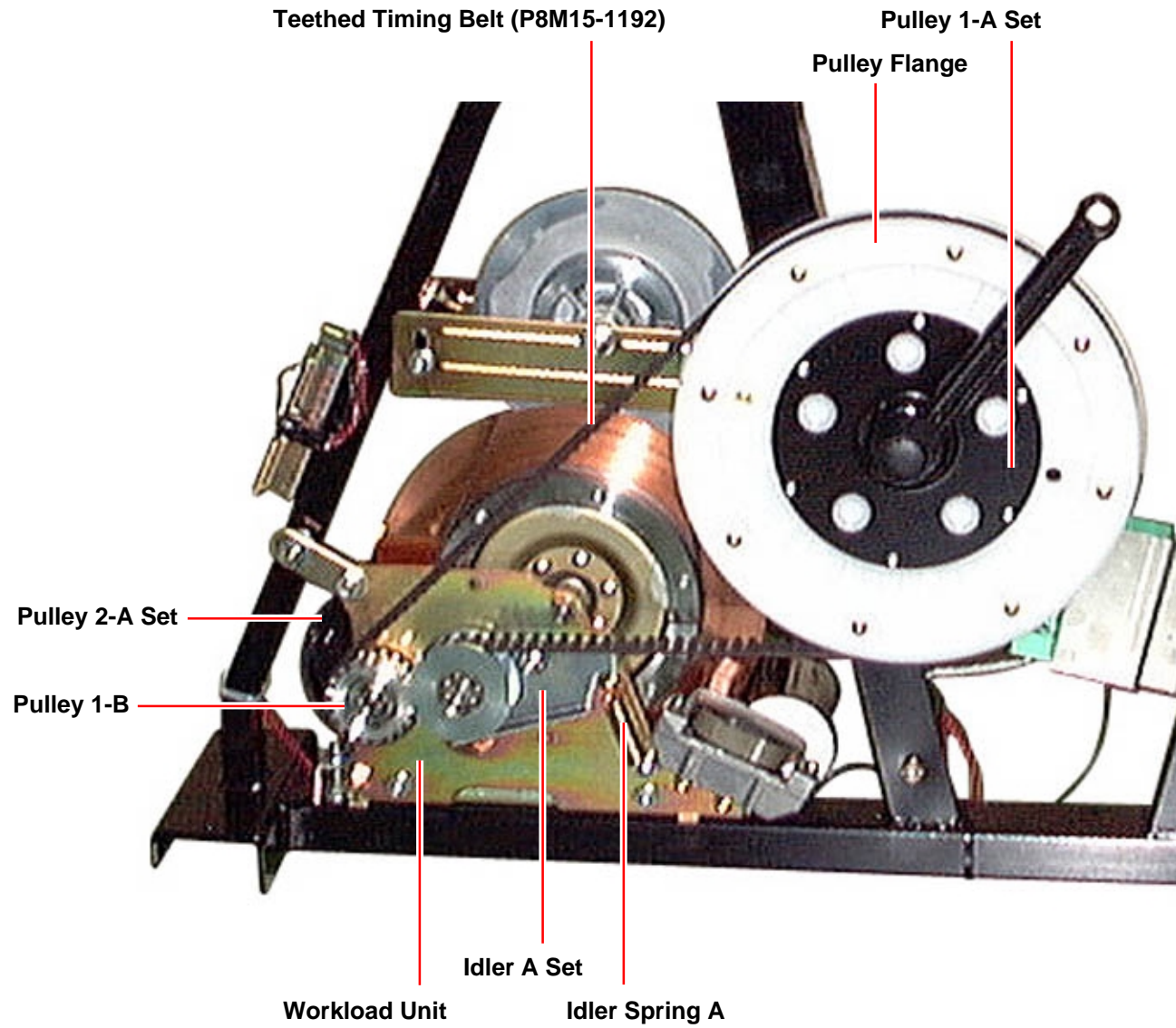

EC-1200B

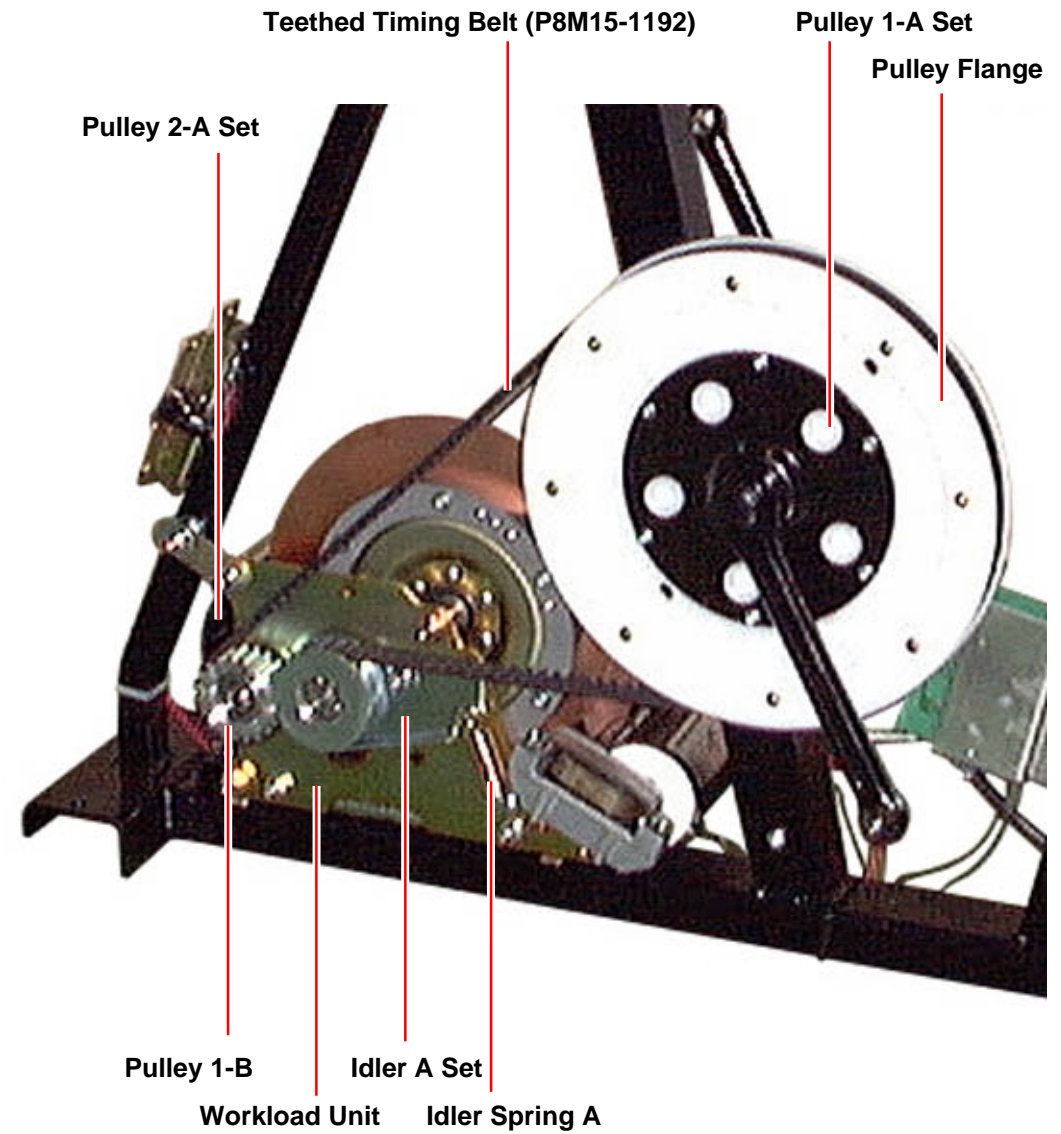

Name of Parts for Belt Drive Type

Belt Drive

EC-3600B/EC-3700B

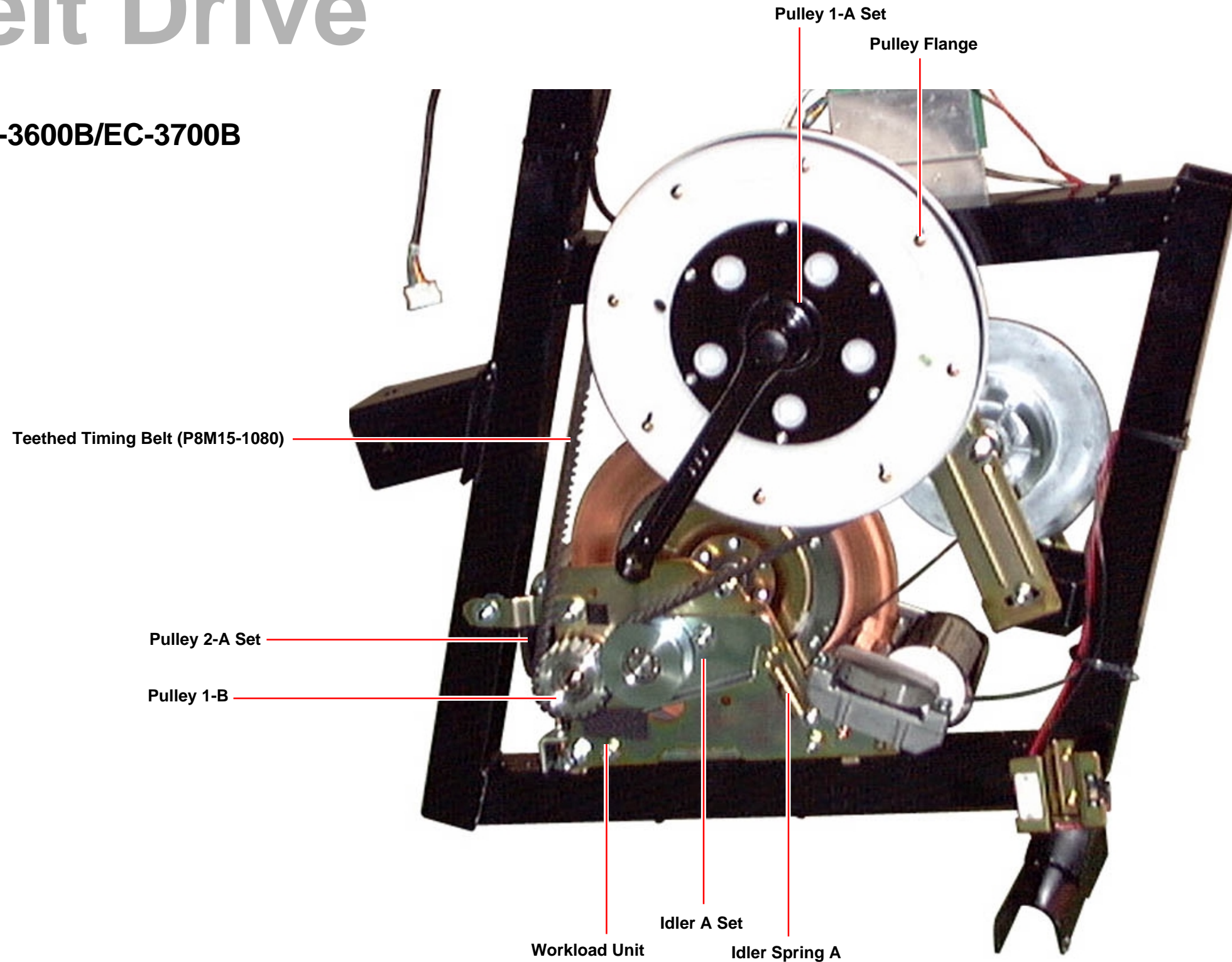

Name of Parts for Belt Drive Type

Circuit Diagram for Automatic Type Cateye Ergociser

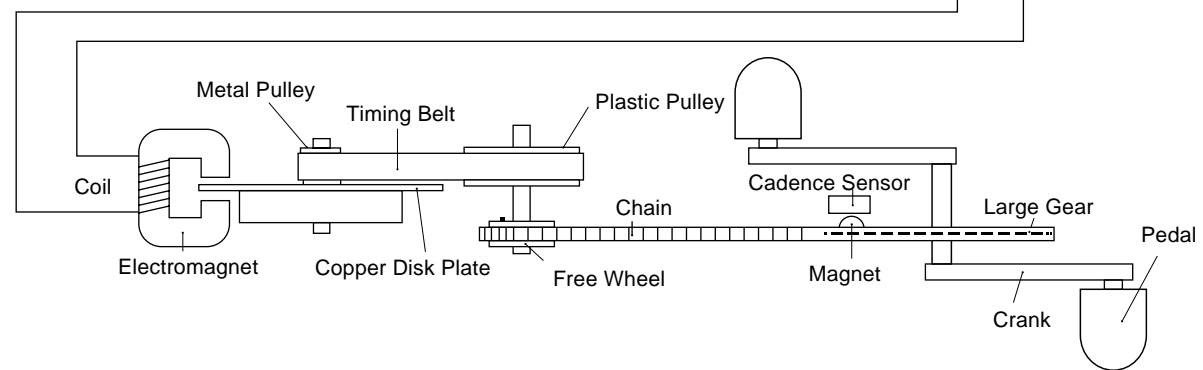
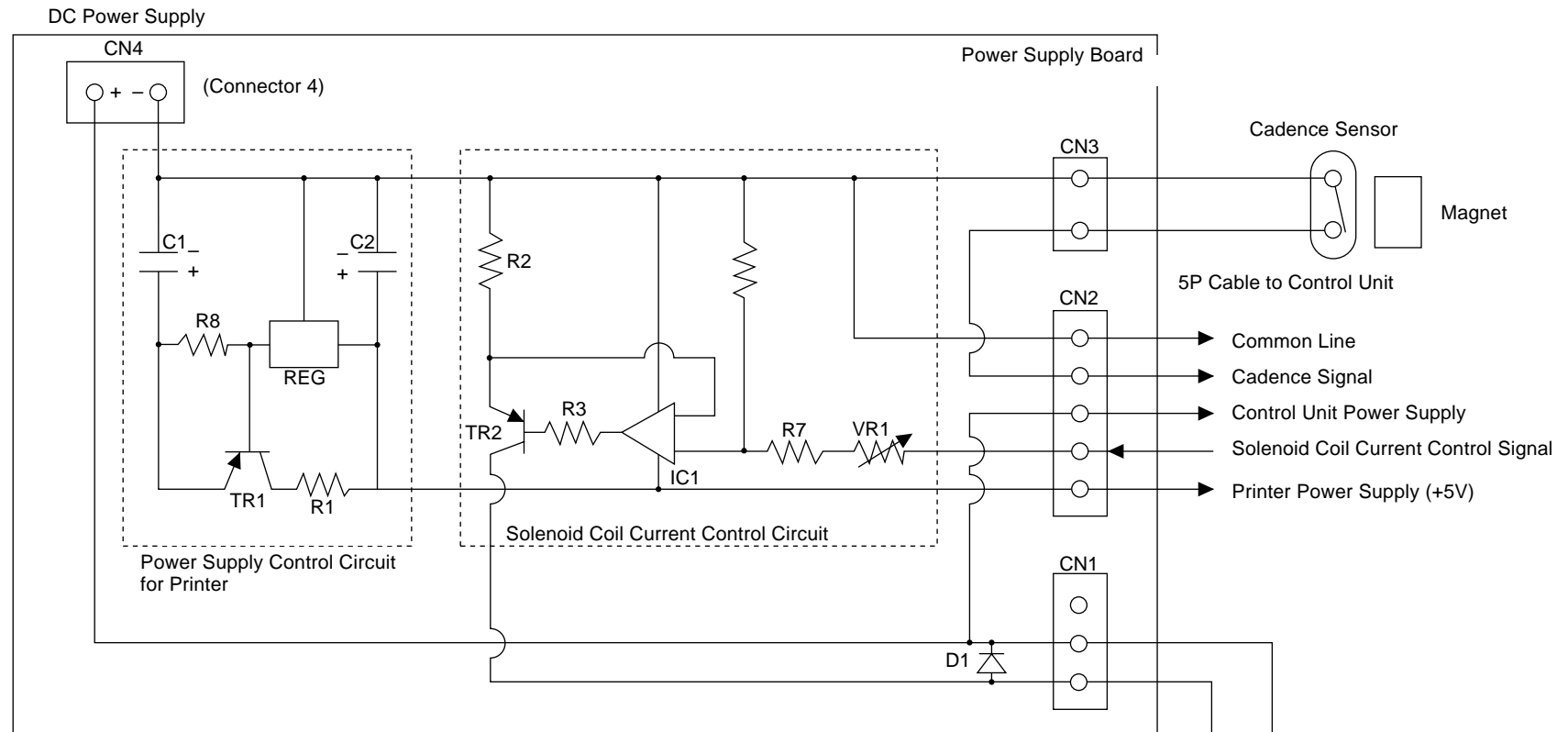
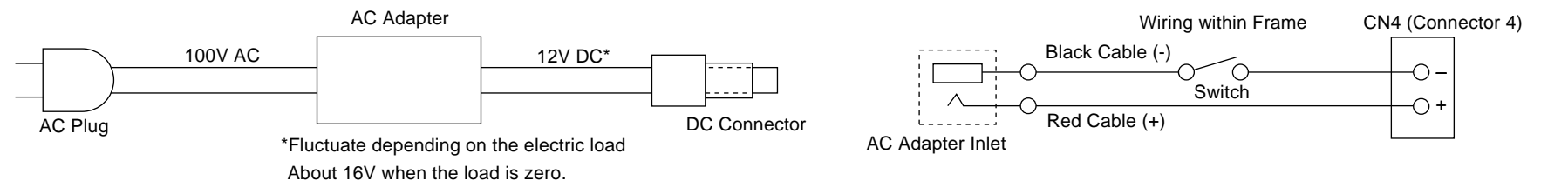

T-1 No Display on Control Unit after Power ON. (1)

Check Method of Causes

Check the power is available at the wall socket before proceeding to checking of causes.

[1] Checking the AC Adapter

1. Detach the plug of AC adapter from the AC adapter inlet of the main unit.
2. Connect the wall socket plug of the AC adapter to the wall socket.
3. Using a tester, measure the voltage at the plug which will be connected to the main unit. (Fig. 1)
 - The AC adapter will be working fine, if the voltage is minus (-) at the inner area and plus (+) at the outer area of the connector and also the meter reading is in the range of 14V and 19V.
 - When the measured voltage is 0V, or less than 14V, the AC adapter will be defective.

Note: Never short-circuit the plug of AC adapter. This will damage the AC adapter.

[2] Checking the Wiring within the Frame

1. When the AC adapter is found to be correct, proceed to checking of wiring within the frame. Loosen the four screws on the handlebar stem to remove the control unit. (Fig. 2)
2. Remove the 5P cable which is connected to the back of the control unit. (Fig. 2)
3. Connect the AC adapter, and turn on the main unit.
4. Using a tester, measure the voltage across the terminals 1 (-) and 3 (+) of the 5P cable. (Fig. 3)
 - The main unit side will be working fine if the meter reading is in the range of 14V and 19V. This means the control unit will be defective.

Repair Method

Replace the AC adapter.

Replace the control unit.

Explanation Figures

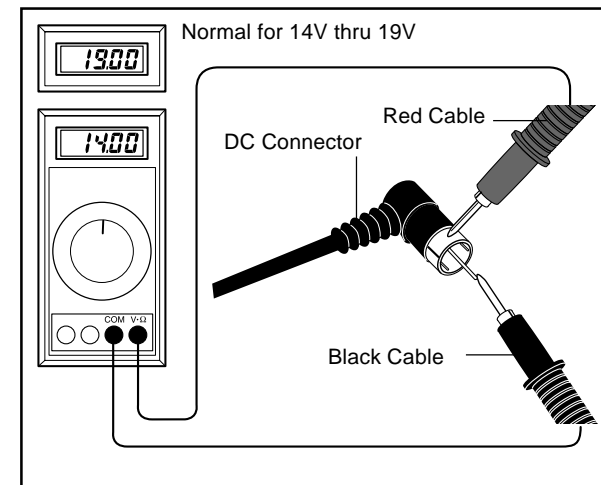

Fig. 1

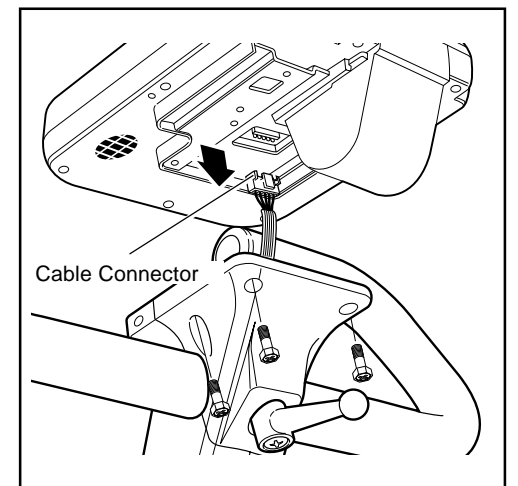

Fig. 2

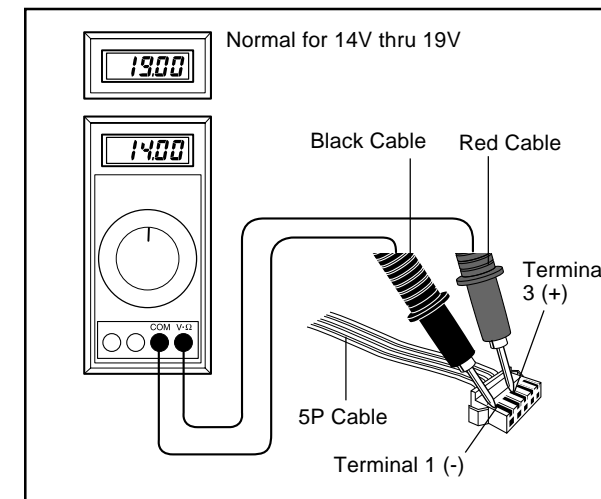

Fig. 3

T-1 No Display on Control Unit after Power ON. (2)

Check Method of Causes

[3] When the meter reading at step 2. is 0V or less than 14V, check the main unit in accordance with the following procedures:

1. Remove the frame cover. (See sections D-1 and D-2 "Removing the Frame Covers.")
2. With the control unit removed, connect the AC adapter, and turn on the power switch. Measure the voltage across the electrolytic capacitor C1 on the power supply board (25V 1000 μ V). (Fig. 4)

Note: The layout of the power supply board may be different from lot to lot. (Figs. 5 and 6)

- The wiring within the frame is correct when the measured voltage is in the range of 14V and 19V. When the voltage across the electrolytic capacitor on the power supply board is correct, the 5P cable, which connects the power supply board and the control unit, may be defective.
- When the measured voltage is 0V, the wiring within the frame is defective.
- When the problem cannot be remedied even if the 5P cable is replaced, the power supply board may be defective.

Repair Method

Replace the 5P cable. (See the Section ES-2 "Replacing the Frame.")

Replace the Inlet Metal Base Set. (See the Section ES-1 "Replacing the Wiring within the Frame.")

Replace the power supply board. (See the Section ES-3 "Replacing the Power Supply Board." "Fig. 4

Explanation Figures

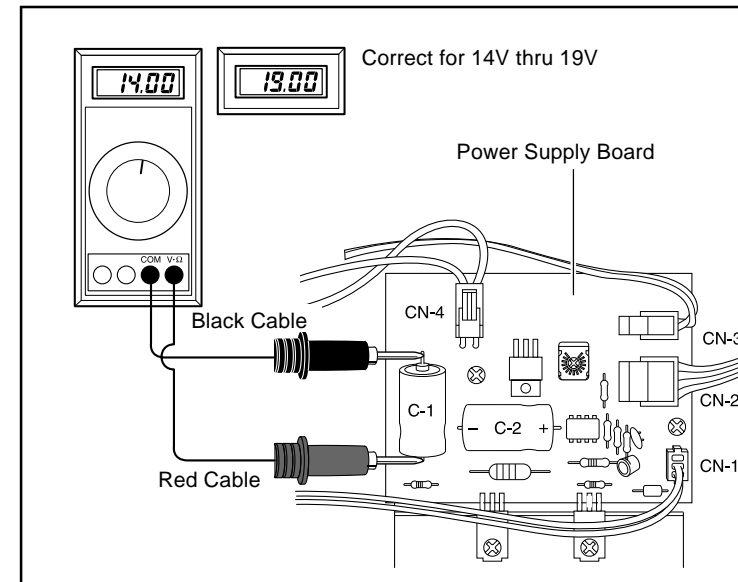

Fig. 4

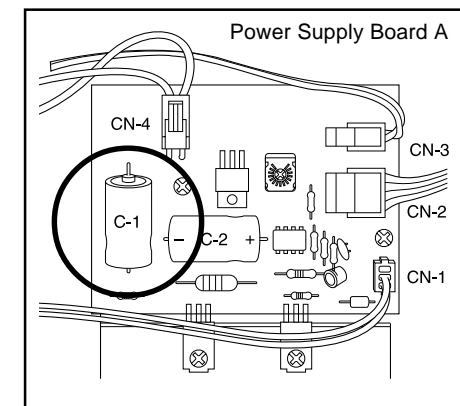

Fig. 5

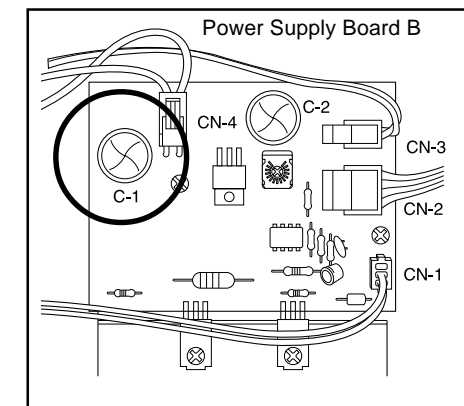

Fig. 6

T-3 No Display of Pulse Rate

Check Method of Causes	Repair Method	Explanation Figures
<p>1. Turn on the power to display the in-training screen (any exercise program).</p> <p>2. Install a brand new pulse sensor, and check if pulse rate will be displayed.</p> <ul style="list-style-type: none"> ● When the pulse rate can be displayed, the pulse sensor is defective. ● When the pulse rate cannot be displayed, the control unit is defective. 	<p>Replace the pulse sensor with a brand new one.</p> <p>Replace the control unit with a brand new one.</p>	

T-3 No Display of Pulse Rate

T-4 No Printer Operation

Check Method of Causes	Repair Method	Explanation Figures
<p>In such cases as display of the LCD panel, etc. operate without problem, but the printer does not operate, the following cases are possible:</p> <p>[1] Checking the Control Unit</p> <ol style="list-style-type: none"> 1. Check that the printer symbol is displayed on the LCD panel and the printer is in a working status. (Fig. 1) 2. Check if the setting of control unit is in the setting that the printer is not used. (Check if the No.4 select switch on the back of the control unit is in the "OFF" position.) (Fig. 2) 3 Check if the thermal paper is not jammed at the printer head. <ul style="list-style-type: none"> ● Remove the thermal paper if it is jammed. (Fig. 3) 4. When no other problems are found, replace the control unit with a brand new one. 5. With the new control unit installed, check the printer operation. <ul style="list-style-type: none"> ● When the printer works fine, the control unit is defective. <p>When the printer does not operate after the above-stated checks, proceed to the following procedures:</p> <p>[2] Checking the Main Unit</p> <ol style="list-style-type: none"> 1. Turn off the power, and loosen the four screws on the handlebar stem to remove the control unit. (Fig. 4) 2. Remove the cable connector which is connected to the back of the control unit. (Fig. 4) 3. Remove the frame cover. (See the Section D1 & D2 "Removing the Frame Covers.") 4. Remove the CN-2 connector on the power supply board. (Fig. 5) 5. Using a tester, check for any short-circuiting across Terminal 1s and Terminal 5s at both ends of the 5P cable which connects the power supply board and the control unit. (Fig. 6) <ul style="list-style-type: none"> ● When there is no shortcircuit, the 5P cable is disconnected. ● When it is short-circuited, the power supply board is defective. 	<p>In case the printer symbol is not indicated on the LCD panel, press the printer button to have the symbol indicated.</p> <p>Replace the control unit with a brand new one.</p> <p>Replace the 5P cable. (See the Section ES-2 "Replacing the 5P Cable.")</p> <p>Replace the power supply board. (See the Section ES-3 "Replacing the Power Supply Board.")</p>	<p>Fig. 1: Control Unit showing the printer symbol on the LCD panel.</p> <p>Fig. 2: Back of Control Unit showing the Select Switch (ON/OFF) and terminals 1, 2, 3, 4.</p> <p>Fig. 3: Tweezer removing jammed thermal paper from the printer head.</p> <p>Fig. 4: Cable Connector being removed from the back of the control unit.</p> <p>Fig. 5: Power Supply Board showing connectors CN-1, CN-2, CN-3, CN-4 and capacitor C-1.</p> <p>Fig. 6: Tester checking for short-circuiting across Connector Terminal 5 and 5P Cable.</p>

T-5 No Loading (Check of mechanical systems)

Check Method of Causes

Repair Method

Explanation Figures

[1] Checking the Mechanical Systems

See the Section D1 & D2 "Removing the Frame Covers" to remove the frame cover, and check the inside of frame.

1. Check if the chain has not been broken. (Fig. 1)
2. Rotate the crank and check if the belt of the workload unit will rotate. (Fig. 2)
3. Check if the free wheel set is not idling. (Fig. 2)
4. Check if the belt (timing belt) of the workload unit has not been broken. (Fig. 2)
5. Check if the plastic pulley of the workload unit has not been broken. (Fig. 2)

- Replace the chain with a brand new one. (See the Section MS-4 "Replacing the Chain.")
- Replace the free wheel with a brand new one. (See the Section MS-5 "Replacing the Free Wheel Set.")
- Spray CRC into the gap as shown in Fig. 2, and rotate the pedal in forward and backward directions.
- Replace the workload unit. (See the Sections MS-1 & MS-2 "Replacing the Workload Unit.")
- Replace the workload unit. (See the Sections MS-1 & MS-2 "Replacing the Workload Unit.")

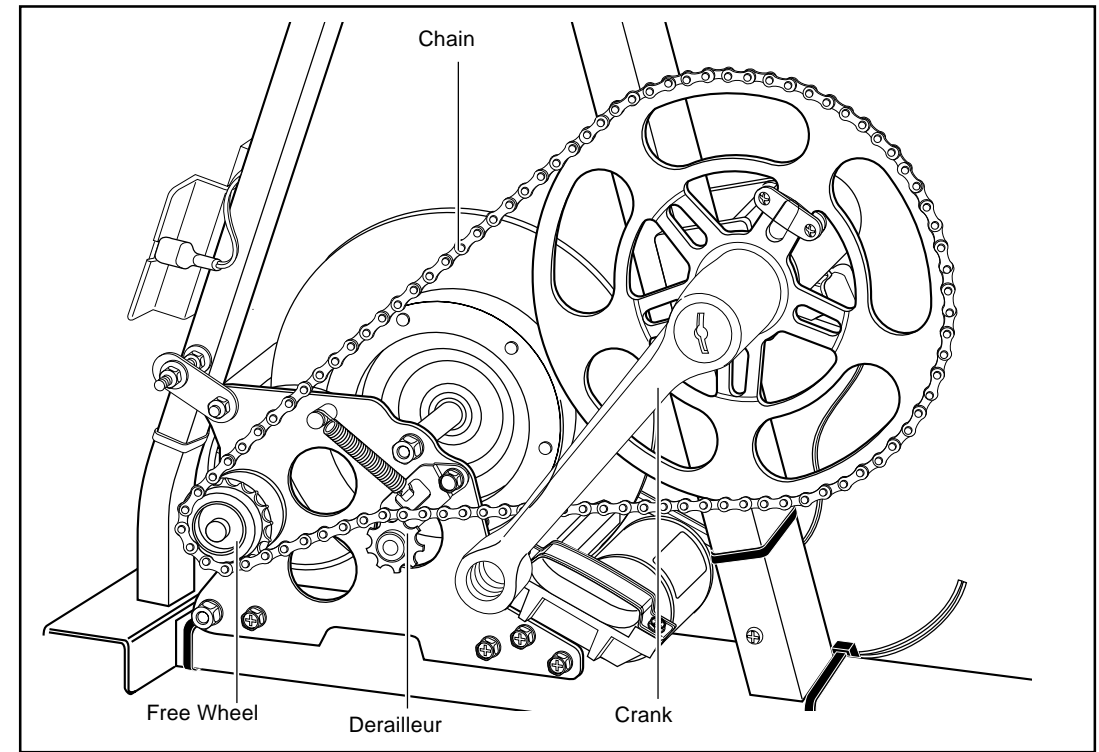

Fig. 1

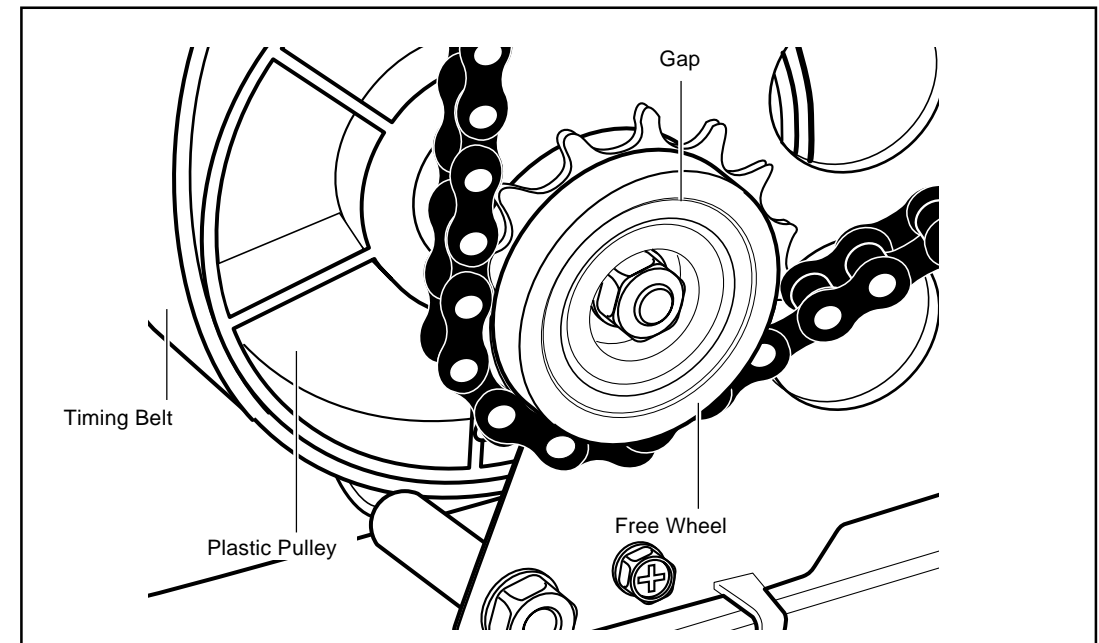

Fig. 2

T-5 No Loading (Check of Electrical Systems)

Check Method of Causes

Repair Method

Explanation Figures

[2]Checking the Electrical Systems

1. Connect the AC adapter, and turn on the power of the main unit.
2. Obtain the manual training program, set the pedal torque setting to 4.0kg-m, and rotate the pedal at the rate of 50 rpm. If you can rotate it quite easily, no load will be applied.
3. Replace the control unit with a brand new one.
4. Again, check the torque status under the manual training program.
 - When the pedal torque is loaded, the control unit is defective.

Replace the control unit with a brand new one.

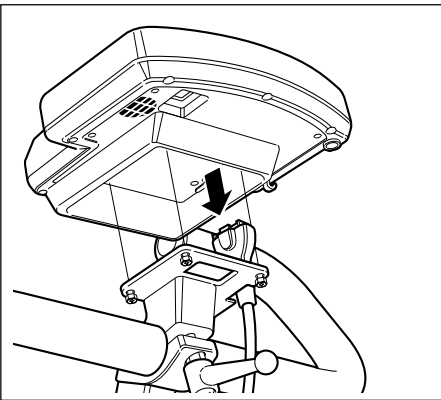

Fig. 1

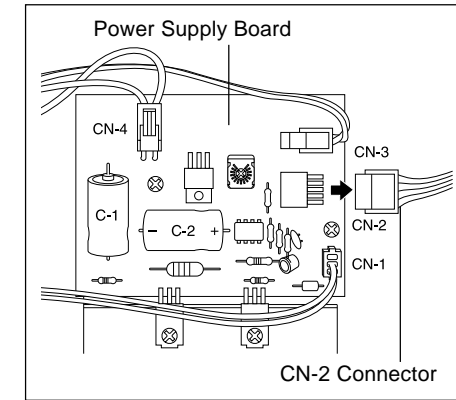

Fig. 2

When no torque loading is possible, proceed to the following procedures.

1. Turn off the power, and loosen the four screws on the handlebar stem to remove the control unit. (Fig. 1)
2. Remove the cable connector which is connected to the back of the control unit. (Fig. 1)
3. Remove the frame cover. (See the Sections D1 & D2 "Removing the Frame Covers.")
4. Remove the CN-2 connector on the power supply board. (Fig. 2)
5. Using a tester, check for any short-circuiting across Terminal 1s and Terminal 4s at both ends of the 5P cable which connects the power supply board and the control unit. (Fig. 3)
 - When there is no shortcircuit, the 5P cable is disconnected.

Replace the 5P cable with a brand new one. (See the Section ES-2 "Replacing the 5P Cable.")

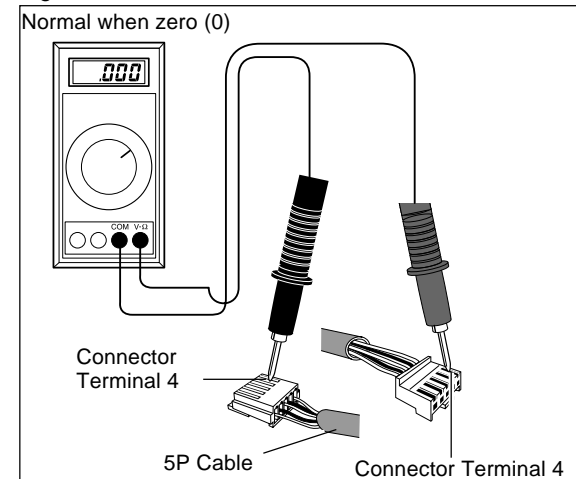

Fig. 3

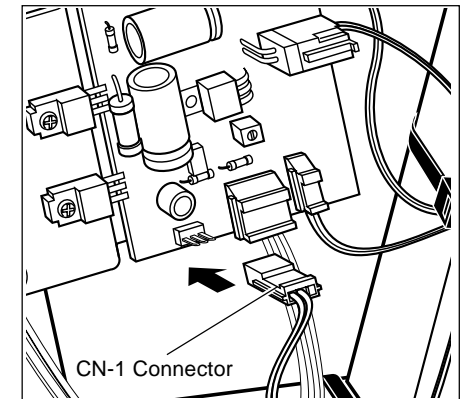

Fig. 4

When it is short-circuited, proceed to the following procedures:

1. Remove the connector CN-1 from the power supply board, and measure the resistance across Terminals 2 and 3 of the connector. When the reading is in the range of 9Ω and 14Ω, the connector is all right. (Figs. 4 & 5)
 - When the meter reading is exceedingly large, the solenoid coil is defective.
 - When the meter reading is in the acceptable range, the power supply board may be defective.

Replace the workload unit. (See the Sections MS-1 & MS-2 "Replacing the Workload Unit.")

Replace the power supply board. (See the Section ES-3 "Replacing the Power Supply Board.")

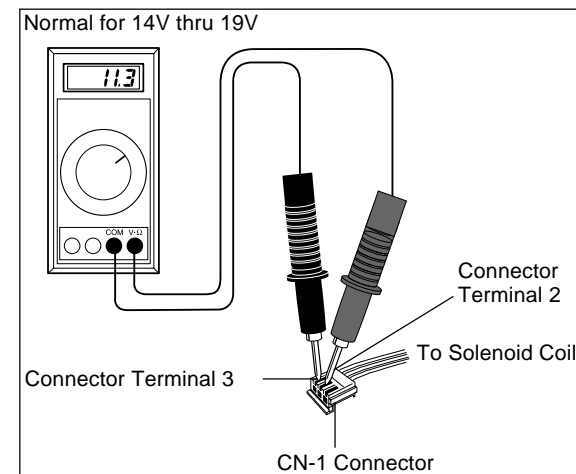
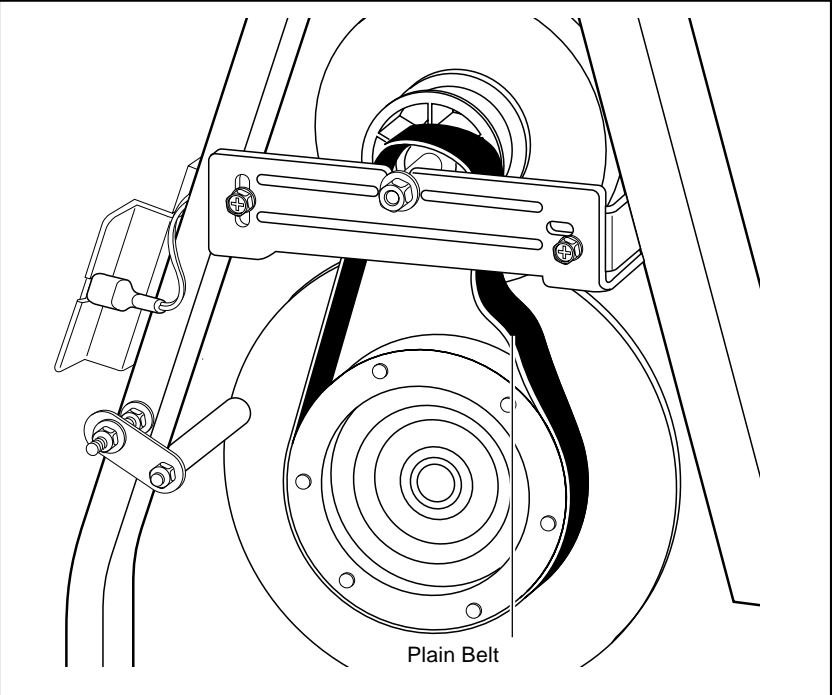
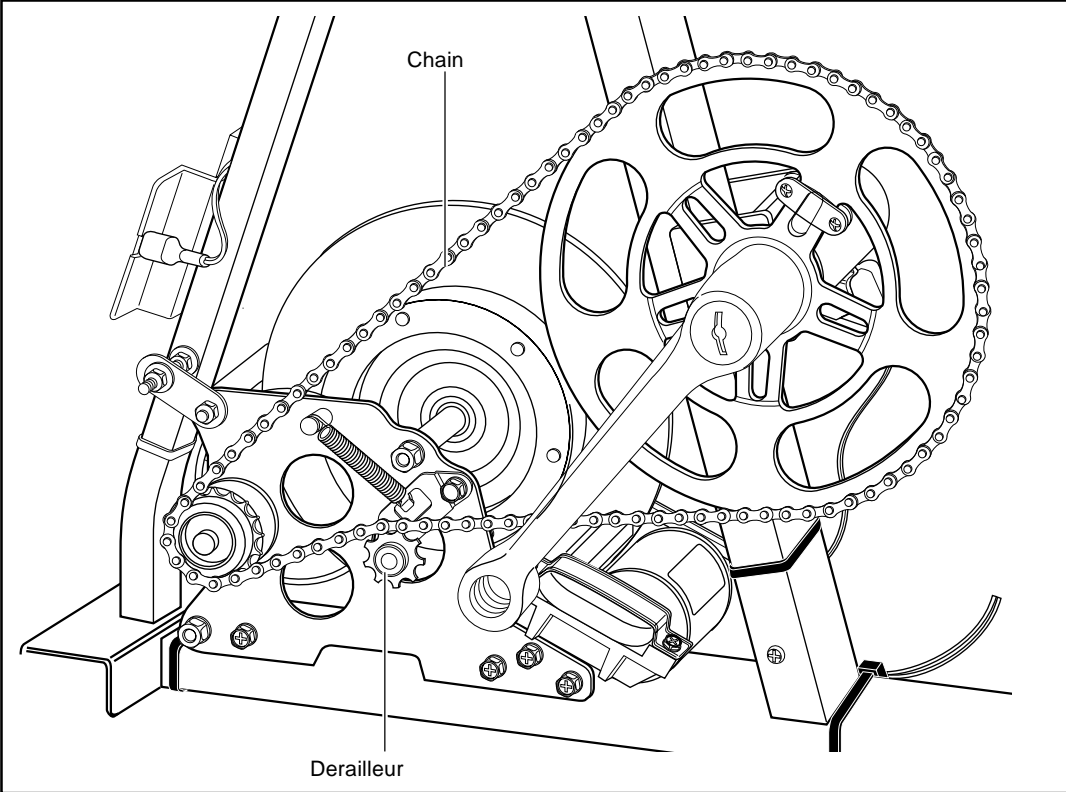
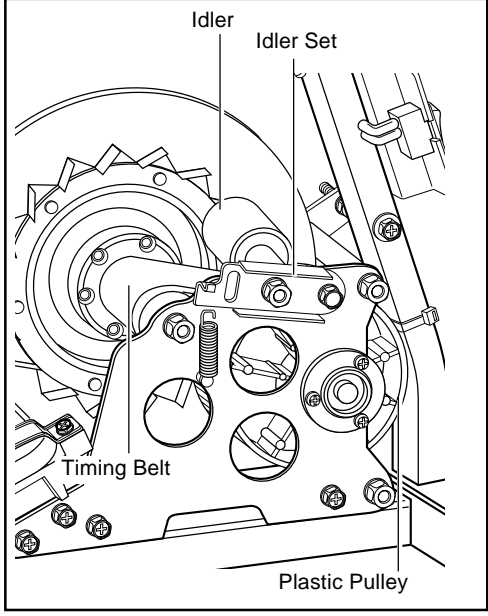
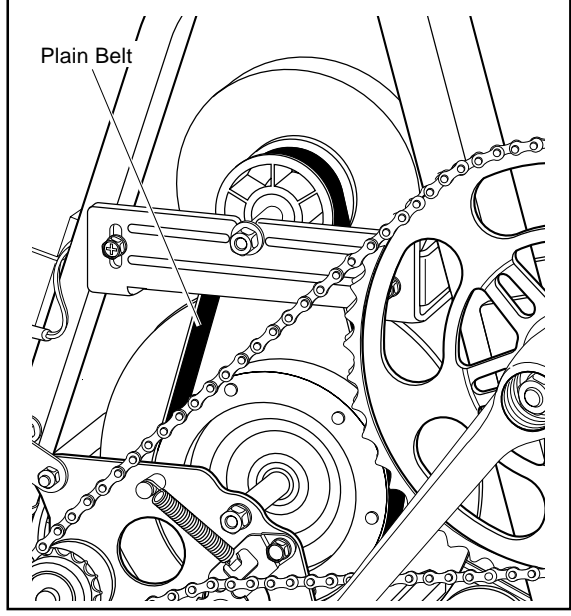

Fig. 5

T-6 No Pedal Rotation (Locked)

Check Method of Causes	Repair Method	Explanation Figures
<p>1. Remove the frame cover, and check the inside of frame. (See the Sections D1 & D2 "Removing the Frame Covers.")</p> <p>2. Check if the plain belt of the flywheel has not been detached. (Fig. 1)</p> <ul style="list-style-type: none"> ● No damage on the plain belt ● The plain belt is damaged. 	<p>Apply the plain belt correctly. (See the Section MS-2 "Replacing the Workload Unit (w/ Flywheel).")</p> <p>Replace the workload unit and free wheel with brand new ones. (See the Section MS-2 "Replacing the Workload Unit (w/ Flywheel).")</p>	 <p>Fig. 1</p>

T-7-1 Unusual Noise (Continuous and Increasing)

Check Method of Causes	Repair Method	Explanation Figures
<p>The noise generating source will be different depending on the cases whether it is of continuous noise or periodical noise (several times per rotation of pedal).</p> <p>[1] Noise is continuous and increasing.</p> <ol style="list-style-type: none"> 1. Remove the frame cover. (See the Sections D-1 & D-2 "Removing the Frame Covers.") <p>Apply grease to the following points. (Figs 1 & 2)</p> <ul style="list-style-type: none"> · Chain · Inner surface of the timing belt (mating surface with the plastic pulley) <ol style="list-style-type: none"> 2. Check if the derailleur has been worn out. (Fig. 1) 3. Check if the idler has been worn out. (Fig. 2) 4. Check if the plain belt has been deviated in position, thus causing friction. 	<p>When it has been worn out, replace it with a brand new derailleur set. (See the Section MS-6 "Replacing the Derailleur Set.")</p> <p>When it has been worn out, replace it with a brand new idler set. (See the Section MS-7 "Replacing the Idler Set.")</p> <p>When the plain belt is shifted and is going to be damaged, replace both the workload unit and the flywheel set with new ones.</p>	 <p>Fig. 1</p>  <p>Fig. 2</p>  <p>Fig. 3</p>

T-7-2 Unusual Noise (Periodical)

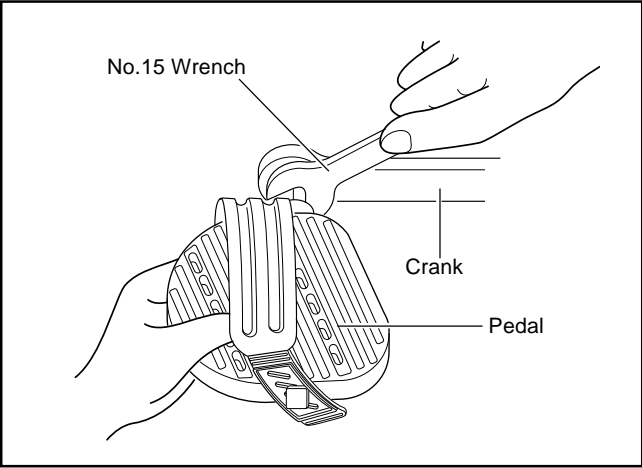
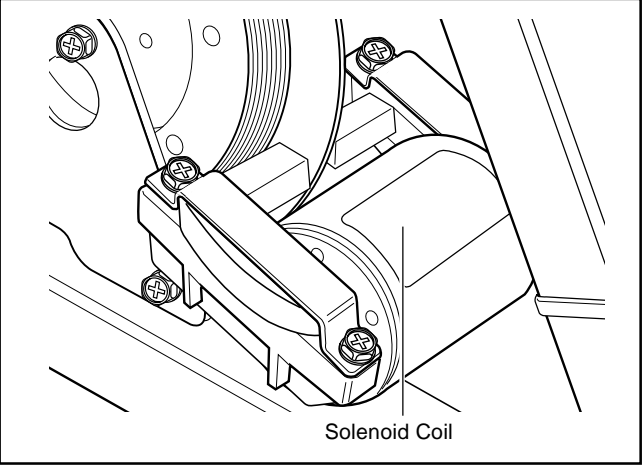
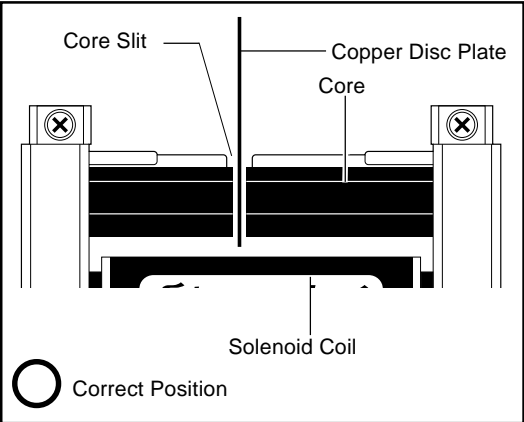
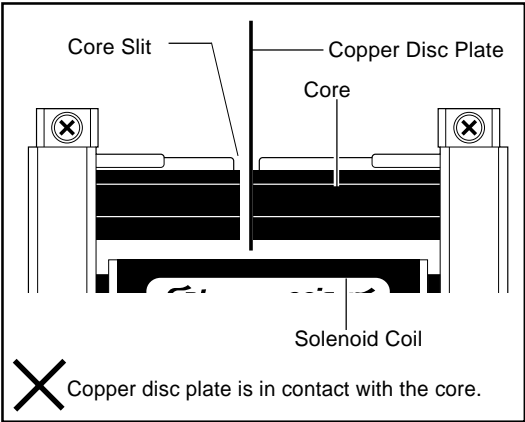
Check Method of Causes	Repair Method	Explanation Figures
<p>[2] Noise is Periodical.</p> <p>1. Noise occurs around once per rotation of the pedal.</p> <ul style="list-style-type: none"> ● The pedal installation may not be perfect. (Fig. 1) <p>2. Sliding noise occurs around 17 times per rotation of the pedal.</p> <p>Remove the frame cover, and check the inside of frame. (See the Sections D-1 & D-2 "Removing the Frame Covers.")</p> <ul style="list-style-type: none"> ● The copper disc plate of the workload unit may touch the solenoid coil. (Figs. 2 & 3) 	<p>Use a No.15 wrench and securely fasten the pedal to the crank. (both sides)</p> <p>See the Section ES-4 "Correcting the Position of Solenoid Coil," and correct the position of the copper disc plate.</p> <p>[If the plate is warped and the position of solenoid coil cannot be corrected, replace the workload unit. (See the Sections MS-1 & MS-2 "Replacing the Workload Unit.")]</p>	 <p>Fig. 1</p>  <p>Fig. 2</p>  <p>Fig. 3</p>  <p>Fig. 4</p>

T-7-2 Unusual Noise

T-7-3 Unusual Noise (Noise occurs when the pedal is rotated with a large torque.)

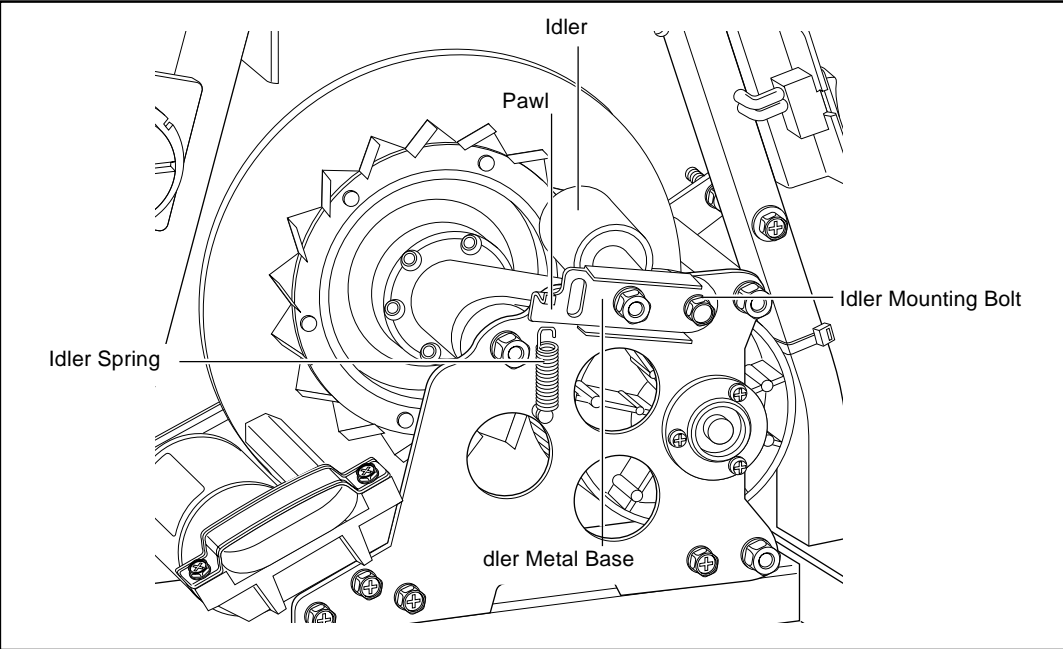
Check Method of Causes	Repair Method	Explanation Figures
<p>[3] Noise occurs when the pedal is rotated with a large torque.</p> <p>A large sound "bang" occurs when the pedal is abruptly rotated with a large torque.</p> <p>Remove the frame cover, and check the inside of frame. (See the Sections D-1 & D-2 "Removing the Frame Covers.")</p> <ol style="list-style-type: none"> 1. Check if the idler spring is detached. 2. Check if the idler mounting bolt is detached or loosened. 	<p>Hook the idler spring on the pawl of the idler.</p> <p>Securely fasten the idler mounting bolt.</p>	 <p>Fig. 1</p>

D-1 Removing the Frame Covers

Upright Type (EC-1200 & EC-1600)

When any repair or adjustment of parts within the frame is required, remove the frame covers in the following procedures.

REMOVAL

1. Remove the pedals at both the left and right sides. (The right side pedal can be removed by turning it in the clockwise direction, and the left side pedal can be removed in the counter-clockwise direction.) (Fig. 1)
2. Remove the crank cover fixing screws. The narrow-width area of the crank cover should be positioned in between the frame cover and the crank. (Fig. 2)
3. Remove the leg pipe fixing screws. (Fig. 3)
 - * You do not have to remove the leg pipe itself.
 - * For the model EC-1600, remove the leg pipe cover.
4. Shift the rubber base at the seat post lock knob away from the center cover.
5. Loosen the center cover fixing screw a little, and lift the center cover upward. (Do not remove it.) (Fig. 4)
6. Loosen the four screws on the inlet cover. (Fig. 5)
7. Remove the frame cover fixing screw with a screwdriver before removing the frame cover. (Fig. 6)

ASSEMBLING

1. Place the frame covers onto the frame at both right and left sides, paying attention to the position of the crank.
2. Fix the right and left frame covers with frame cover fixing screws.
3. Mount the inlet cover with four screws. (Fig. 5)
4. Set the center cover to the frame cover correctly in position, and fix it with the center cover fixing screws. (Fig. 4)
5. Pass the crank through the hole on the crank cover, and fix the crank cover onto the frame cover with screws. (Fig. 2)
6. Set the rubber base for the seat post lock knob, and then mount the right and left pedals.
7. Fix the leg pipe with the leg pipe fixing screws. (For the model EC-1600, mount the leg pipe cover.)

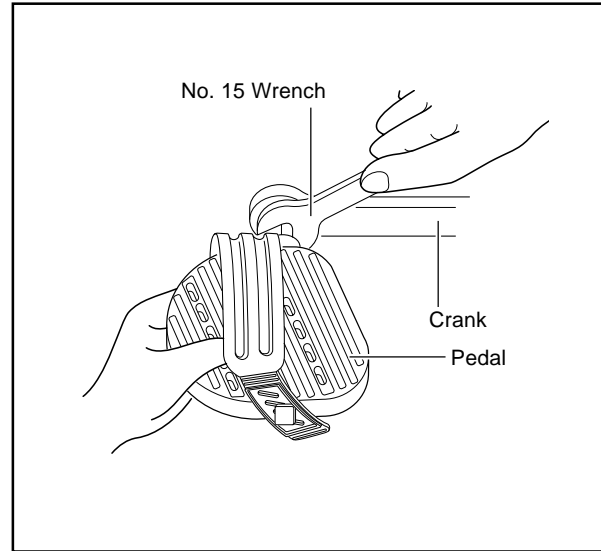

Fig. 1

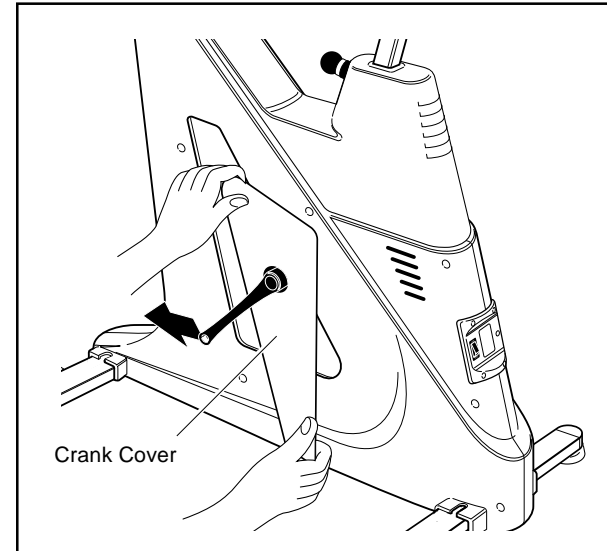

Fig. 2

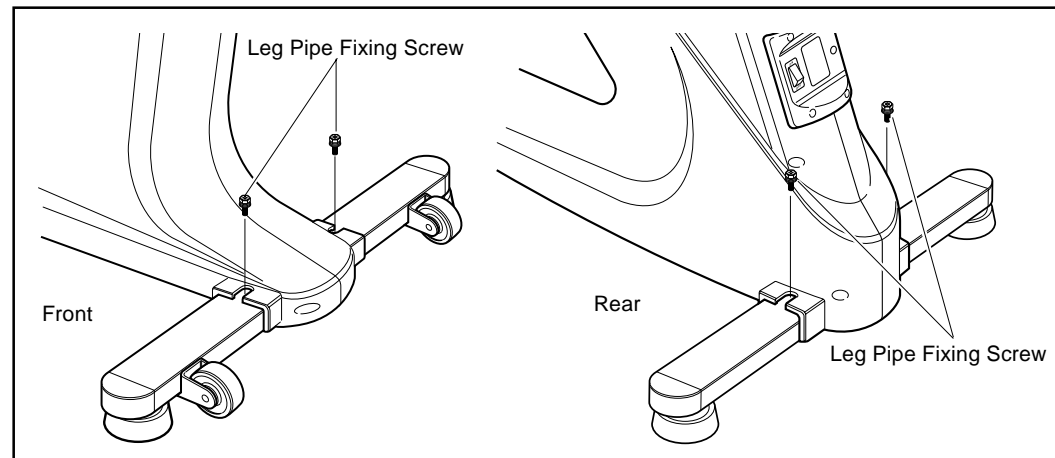

Fig. 3

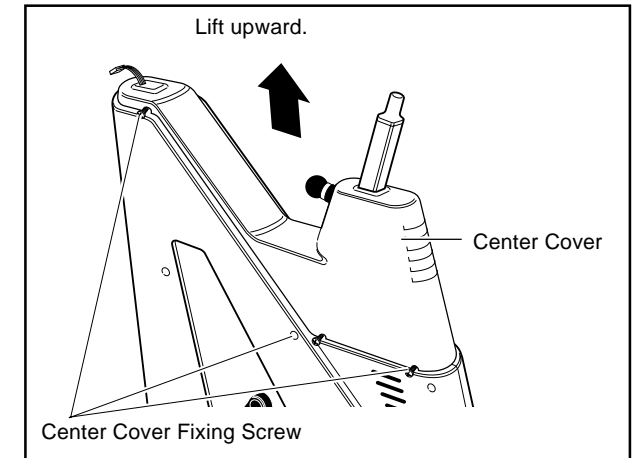

Fig. 4

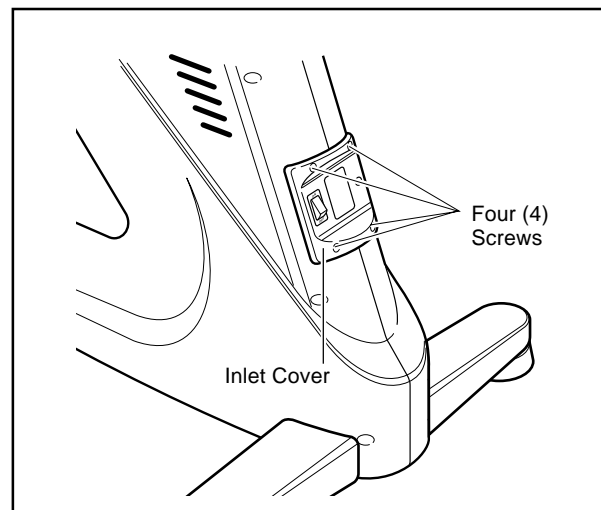

Fig. 5

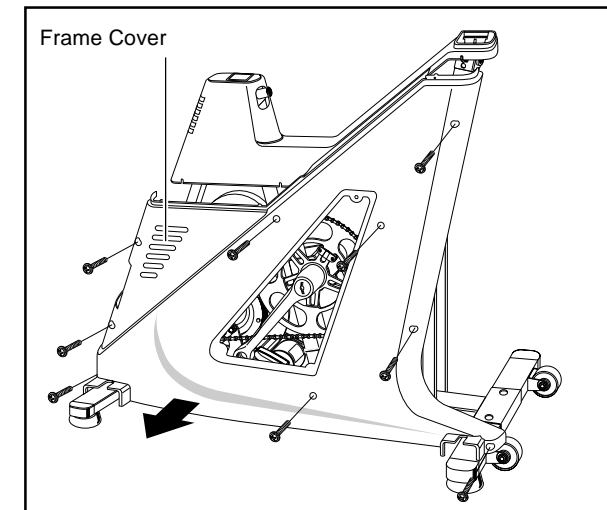

Fig. 6

D-2 Removing the Frame Covers

Recumbent Type (EC-3600 & EC-3700)

When any repair or adjustment of parts within the frame is required, remove the frame covers in the following procedures.

REMOVAL

1. Remove the pedals at both the left and right sides. (The right side pedal can be removed by turning it in the clockwise direction, and the left side pedal can be removed in the counter-clockwise direction.) (Fig. 1)
2. Remove the crank cover fixing screws. The narrow-width area of the crank cover should be positioned in between the frame cover and the crank. (Fig. 2)
3. Remove the leg pipe fixing screws. (Fig. 3)
 - * You do not have to remove the leg pipe itself.
4. Remove the frame cover fixing screw with a screwdriver before removing the frame cover. (Fig. 4)

ASSEMBLING

1. Place the frame covers onto the frame at both right and left sides, paying attention to the position of the crank. At the same time, the center cover should be built in.
2. Fix the right and left frame covers with frame cover fixing screws.
3. Pass the crank through the hole on the crank cover, and fix the crank cover onto the frame cover with screws. (Fig. 2)
4. Fix the front leg with casters with the leg pipe fixing screws.
5. Mount the pedals.

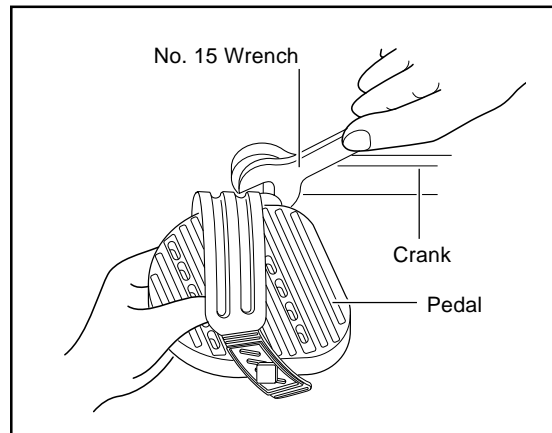

Fig. 1

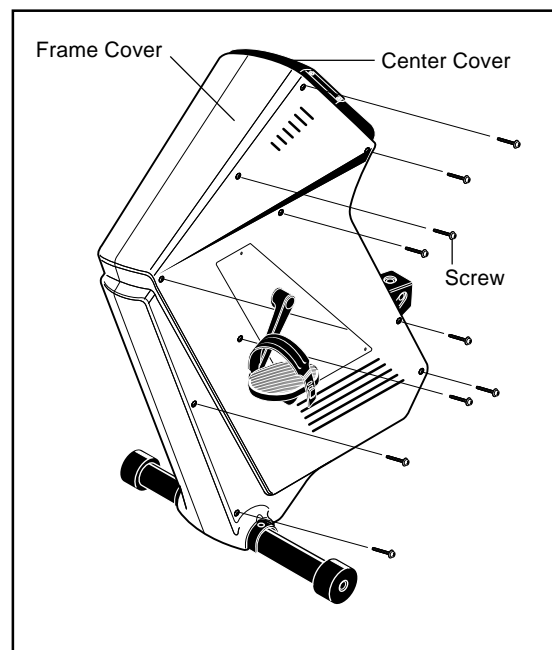

Fig. 4

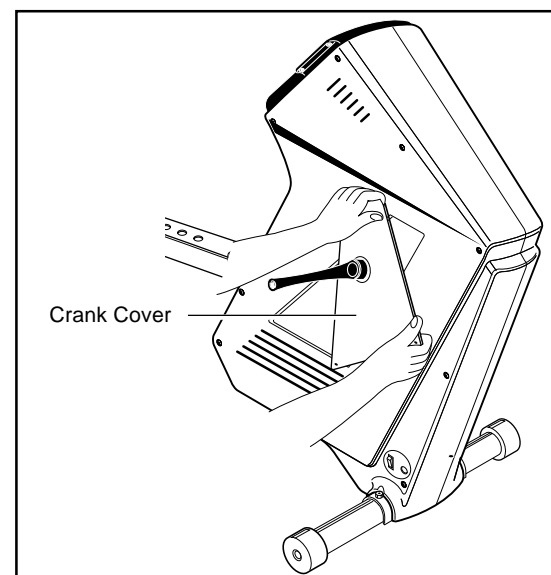

Fig. 2

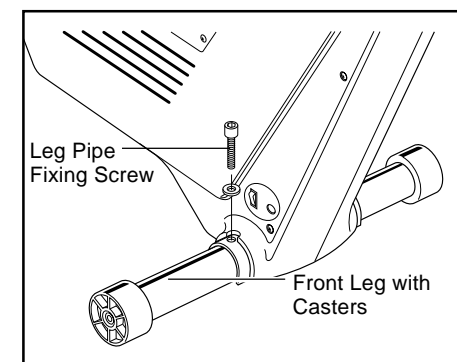

Fig. 3

ES-1 Replacing the Wiring within the Frame

[A] Removing the Wiring Parts

1. Remove the frame cover. (See the Sections D-1 & D-2 "Removing the Frame Covers.")
2. Loosen the two screws on the inlet metal base to remove them. (Fig. 1)
3. With the stopper being held with fingers, pull the CN-4 connector off the power supply board. (Fig. 2)
4. Cut the cable holder with a nipper. (Fig. 3)

[B] Mounting the Brand New Wiring Parts

1. Mount the brand new inlet metal base to the frame with two screws.
2. Pass the wiring cable from beneath the DC jack of the power supply board along with the square pipe (21mm x 21mm) to the left direction, and then pass it through the back of the inlet metal base along with the square pipe toward the switch.
3. Connect the CN-4 connector to the power supply board.
4. Refer to the Section (2) "Checking the Wiring within the Frame" of T-1 "No Display on the Control Unit after Power ON" (1), measure the voltage across the electrolytic capacitor C-1 to check that it is in the correct range of 14V and 19V.
5. Use the cable holder to fix the CDC sensor cable together with the solenoid coil cable. (Fig. 3)
6. Provisionally connect the control unit, and check the unit works fine after turning on the power. Then, completely assemble the frame cover.

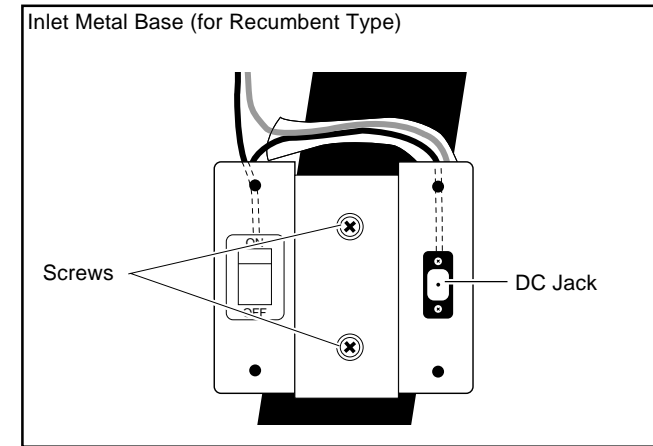
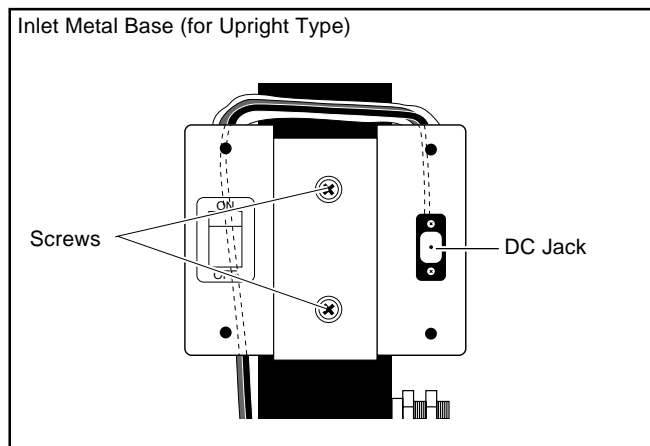
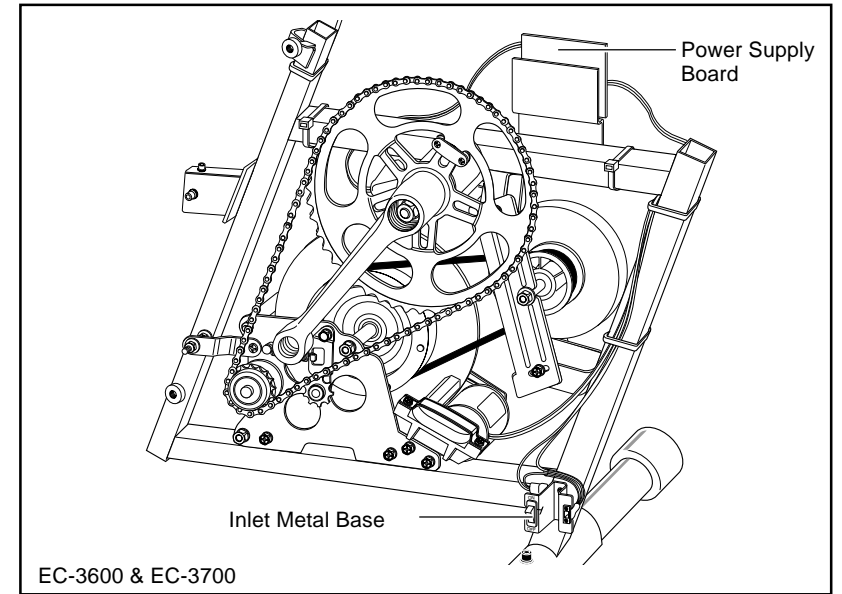
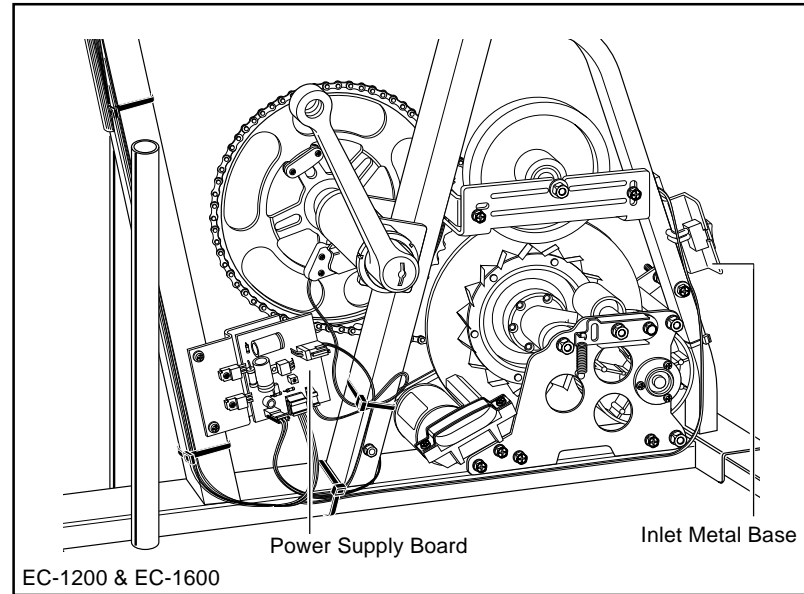

Fig. 1

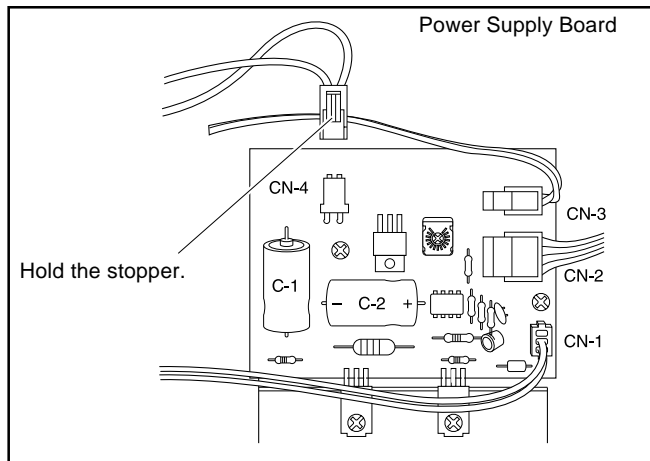

Fig. 2

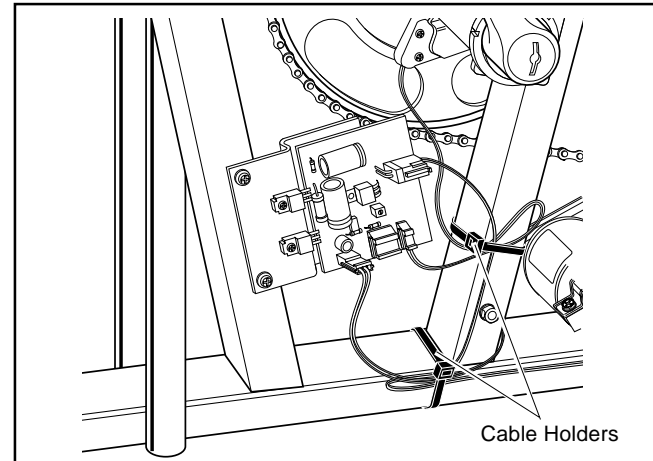

Fig. 3

ES-2 Replacing the 5P Cable (1)

Procedures are different depending on the type of model as shown below:

■ Upright Type (EC-1200)

○ Removing the Existing Cable

1. Loosen the four screws which fix the control unit to remove the control unit. Also, remove the cable connector. (Fig. 1)
2. Remove the cable holder which fixes the 5P cable to the handlebar post.
3. Remove the frame cover. (See the Section D-1 "Removing the Frame Covers.")
4. Remove the CN-2 connector from the power supply board. (Fig. 2)
5. Cut the cable holders which fix the 5P cable to the frame, and remove the 5P cable.

○ Mounting the Brand New Cable

1. Mark the 5P cable at a point approx. 87cm from the unit-side cable connector (Fig. 3), and connect the leading end of the CN-2 connector to the power supply board.
2. (1) Using cable holders, fix the 5P cable at the bottom of the handlebar pipe of the main unit frame. (2) Fix the cable at the marked point of the cable to the handlebar pipe just beneath the horizontal frame. (3) Pass the 5P cable along with the handlebar pipe, and the sagging portion should be bound with a cable holder. (Fig. 4)
3. Connect the cable connector to the control unit, and apply the connector cover. Then, fix the control unit to the handlebar post by using four screws. (Fig. 1)
4. Provisionally turn on the power, and check if the control unit works fine.
5. Fix the 5P connector to the handlebar post with the cable holder.
6. Mount the frame cover. (See the Section D-1 "Removing the Frame Covers.")

■ Upright Type (EC-1600)

○ Removing the Existing Cable

5P Cable Handlebar Post

1. Loosen the four screws which fix the control unit to remove the control unit. Also, remove the cable connector. (Fig. 4) Slide the inner handlebar post cover upward, and unplug the cable connector. (Fig. 5)
2. Remove the screws of both the handlebar stem and the outer handlebar post cover to remove the 5P cable. (Fig. 6)

5P Cable within the Frame

1. Remove the frame cover. (See the Section D-1 "Removing the Frame Covers.")
2. Remove the CN-2 connector at the end of the 5P cable from the power supply board.
3. Cut the cable holders which fix the 5P cable to the handlebar pipe, and remove the 5P cable.

To be continued on the next page.

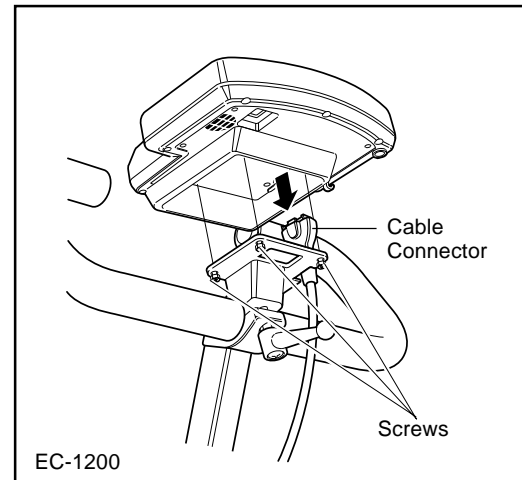

Fig. 1

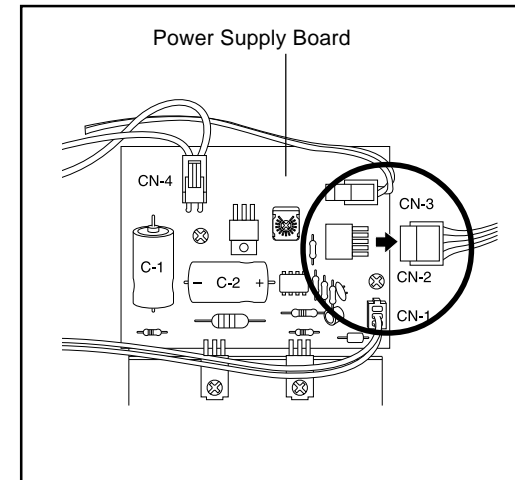

Fig. 2

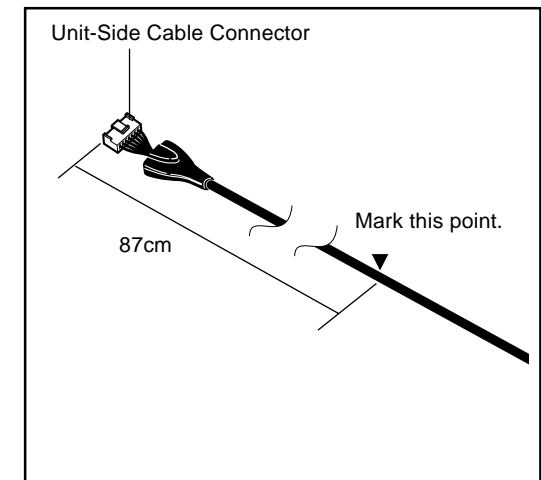

Fig. 3

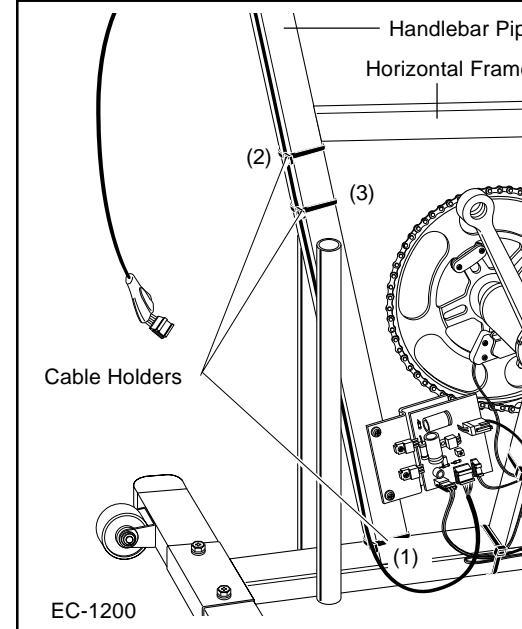

Fig. 4

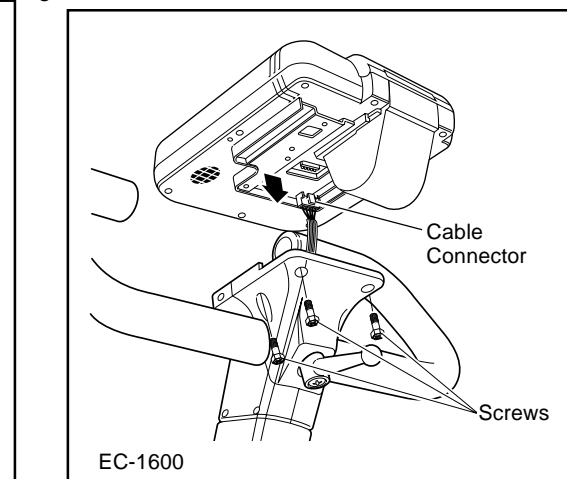

Fig. 5

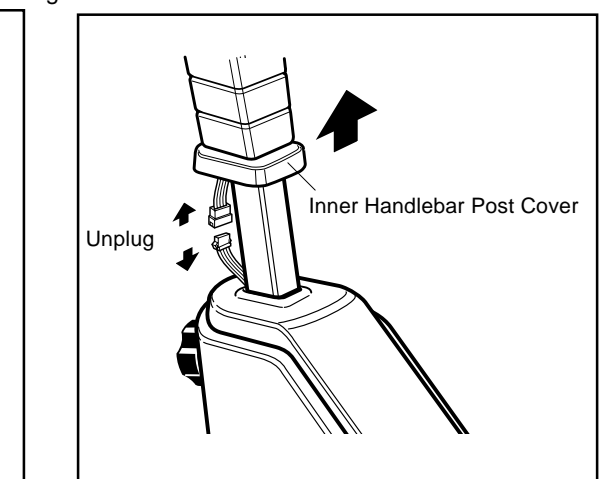

Fig. 6

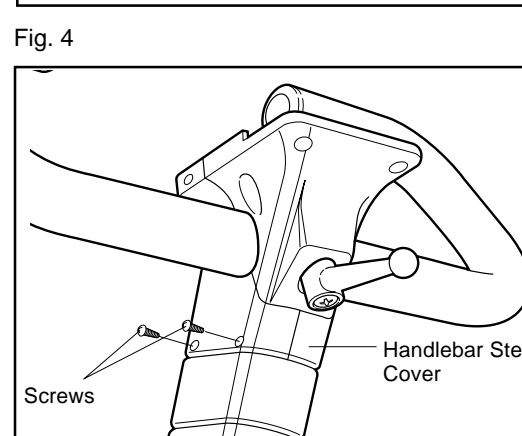

Fig. 7

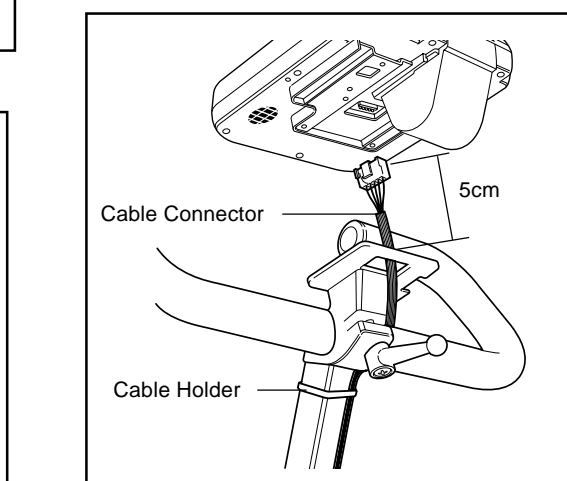

Fig. 8

ES-2 Replacing the 5P Cable (2)

⊙ Mounting the Brand New Cable

5P Cable within the Handlebar Post

1. Using cable holders, bind the 5P cable, leaving approx. 5cm portion from the control unit side cable connector, to the handlebar post. (Fig. 7) Assemble the handlebar post cover and the handlebar stem cover. (Fig. 6)
2. Connect the cable connector to the control unit, and fix the unit to the handlebar post by using four screws. (Fig. 5)

5P Cable within the Frame

1. Connect the CN-2 Connector at the end of the 5P cable to the power supply board.
2. (1)Using cable holders, fix the 5P cable to the frame, leaving the extra portion of 10cm from the top of the handlebar pipe.(2) Fix the 5P cable at the bottom of the handlebar pipe.(3) Pass the 5P cable along the handlebar pipe, and bind the sagging portion to the point (3) by using cable holders. (Fig. 8)
3. Provisionally connect the intermediate cable connector, and turn on the power. Then, check if the control unit works fine.
4. Mount the frame cover to restore the original shape. (See the Section D-1 "Removing the Frame Covers.")

■ Recumbent Type (EC-3600 and EC-3700)

⊙ Removing the Existing Cable

1. Loosen the four screws which fix the control unit to remove the control unit. Also, remove the cable connector. (Fig. 10)
2. Remove the frame cover. (See the Section D-2 "Removing the Frame Covers.")
3. Remove the 5P connector from the power supply board. (Fig. 2)
4. Cut the cable holders which fix the cable to remove the 5P cable.

⊙ Mounting the Brand New Cable

1. Leaving approx. 30cm from the end of the frame, fix the 5P cable to the frame by using cable holders.
2. Connect the 5P cable to the power supply board, and bind the sagging portion to the point (2) of the frame. (Fig. 11)
3. Provisionally turn on the power, and check if the control unit works fine.
4. Mount the frame cover. (See the Section D-2 "Removing the Frame Covers.")

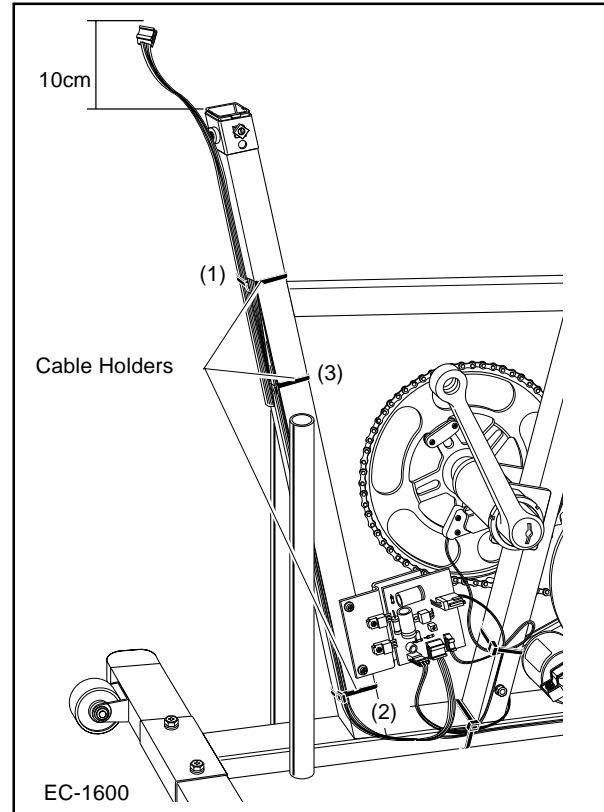

Fig. 9

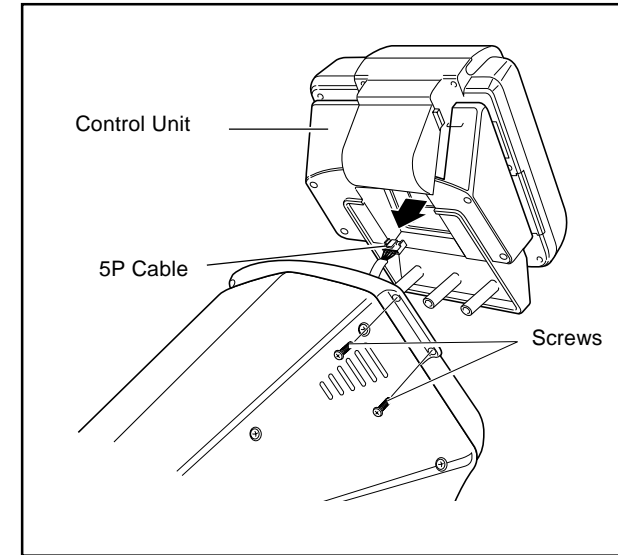

Fig. 10

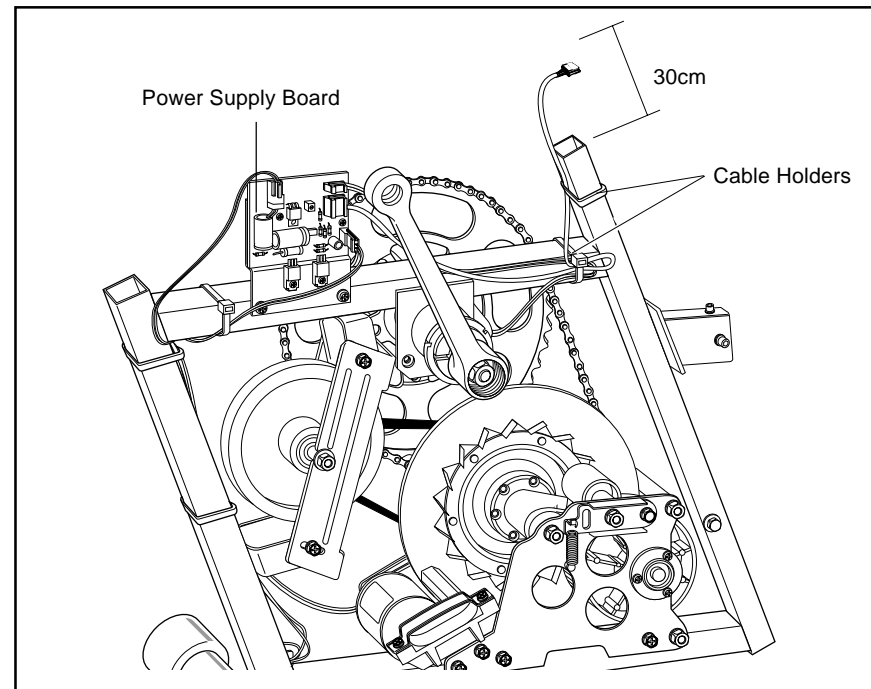
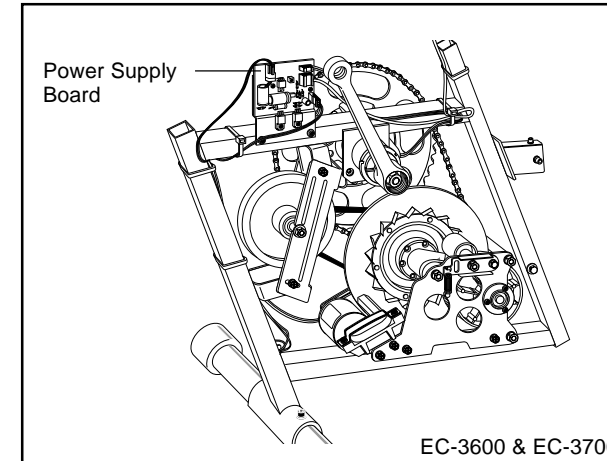
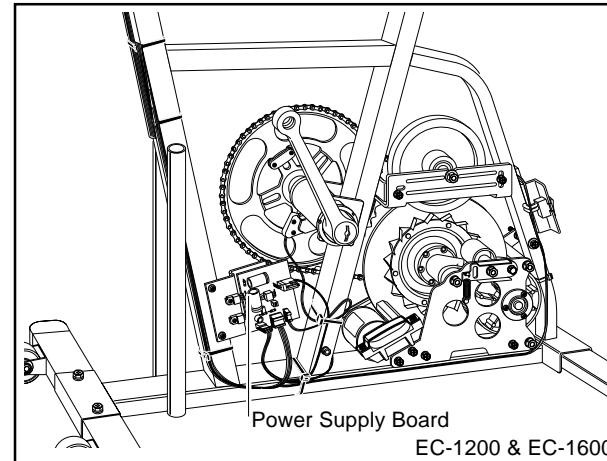

Fig. 11

ES-3 Replacing the Power Supply Board

[1] Replacing the Power Supply Board

1. Remove the frame cover. (See the Sections D-1 & D-2 "Removing the Frame Covers.")
2. Remove all connectors CN-1, CN-2, CN-3 and CN-4 which are connected to the power supply board.
3. Loosen the two screws which fix the power supply board to remove the board. (Fig. 1)
4. Securely fix the brand new power supply board by using two fixing screws.
5. Connect three connectors, CN-2, CN-3 and CN-4.



[2] Adjustment of Coil Current Value

1. Connect the cables for measuring coil current between the female connector of the solenoid coil and the male connector (CN-1) on the power supply board, and then connect the cables to an ammeter. (Fig. 2)
2. Turn on the power switch of the main unit, set the control unit to the manual mode, set the load display to 4.0kg m, and start the system.
3. Adjust the potentiometer (as shown in Figs. 3 and 4) on the power supply board with a blade-head screwdriver so that the coil current will be the value indicated on the workload unit solenoid coil. (A clockwise turn will increase the current, while a counter-clockwise turn will reduce the current.)

Example: When the indication is 630 as shown in Fig. 5, adjust the potentiometer so that the coil current value will be 630mA.

4. Upon completion of the adjustment, detach the cable for measuring coil current, and connect the CN-1 connector directly to the power supply board.

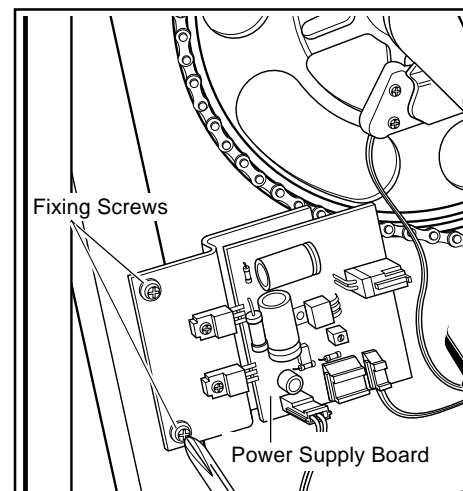

Fig. 1

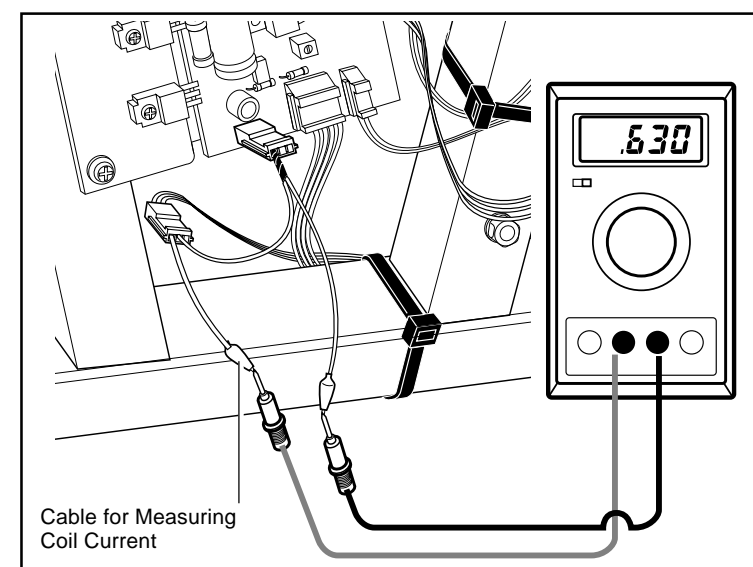

Fig. 2

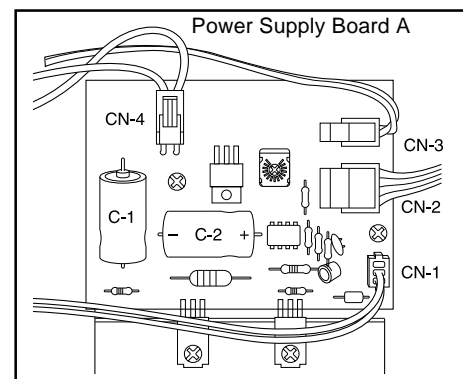

Fig. 3

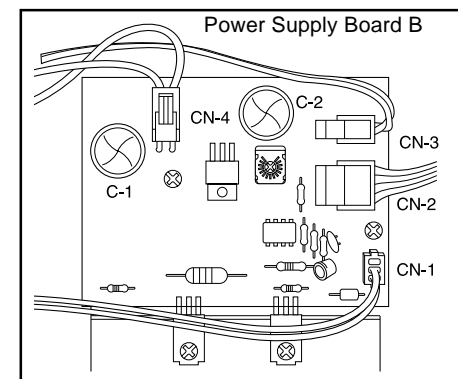

Fig. 4

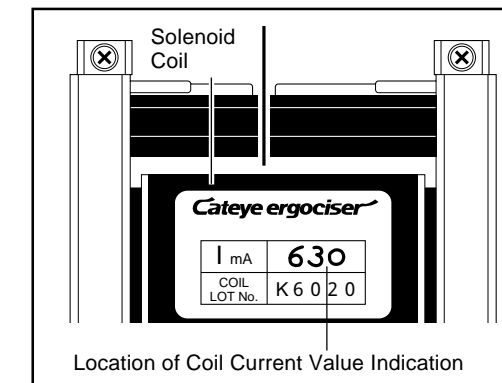

Fig. 5

ES-4 Correcting the Position of Solenoid Coil

Perform the positional correction of the core slit section after detaching the frame cover and turning off the power. (See the Sections D-1 & D-2 "Removing the Frame Covers.")

[1] Correction with Nuts of Workload Unit Reinforcing Metal Base

This correction is a minor correction method which allows adjustment by the fastening force of the frame-side nuts of the workload unit reinforcing metal base.

1. Check the contacting area by slowly rotating the copper disk plate with your hands.
2. Adjust the two frame-side nuts of the workload unit reinforcing metal base in the following procedures. (Fig. 1)
 - A. Loosen the nut on the workload unit side, and the nut on the frame side (Fig. 1).
 - B. If the right side of the copper disk plate contacts the core, when the main unit is viewed from the direction as depicted in Fig. 3, fasten the frame-side nut.
 - C. Then, fasten the frame-side nut on the other side until the copper disk plate comes close to the center of the core slit (Fig. 2). [Rotate the copper disk plate slowly, and check for any contacts on the entire area of the plate.
 - D. Fasten the nuts which had been tightened in the above step A.

[2] In case correction is not possible by the method stated in [1].

Replace the whole workload unit. (See the Section MS-2 "Replacing the Workload Unit (w/ Flywheel).")

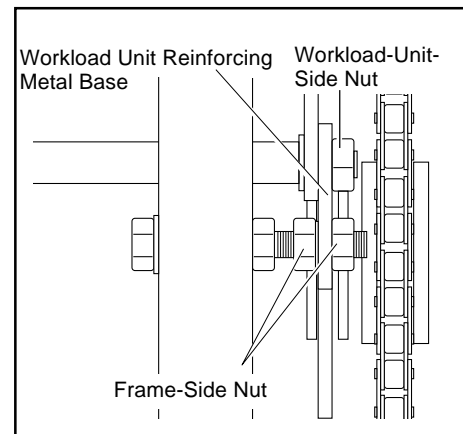
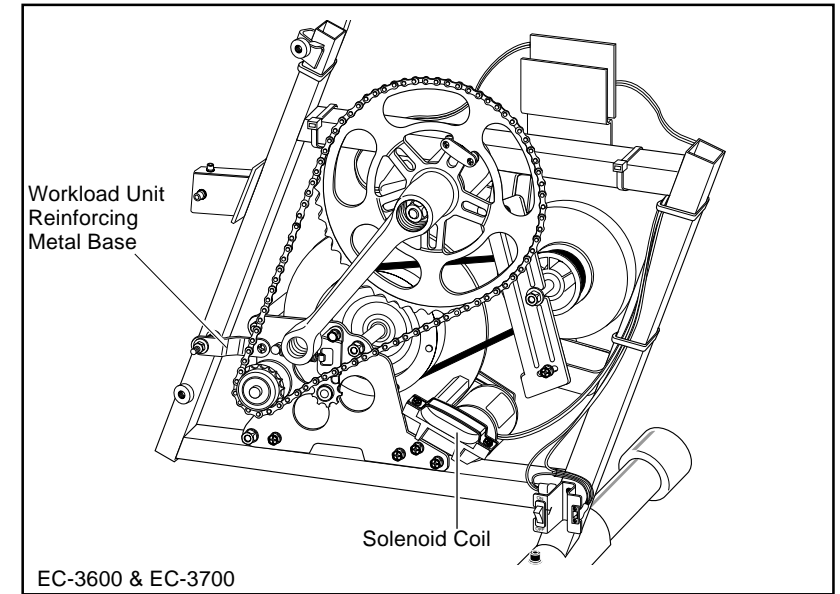
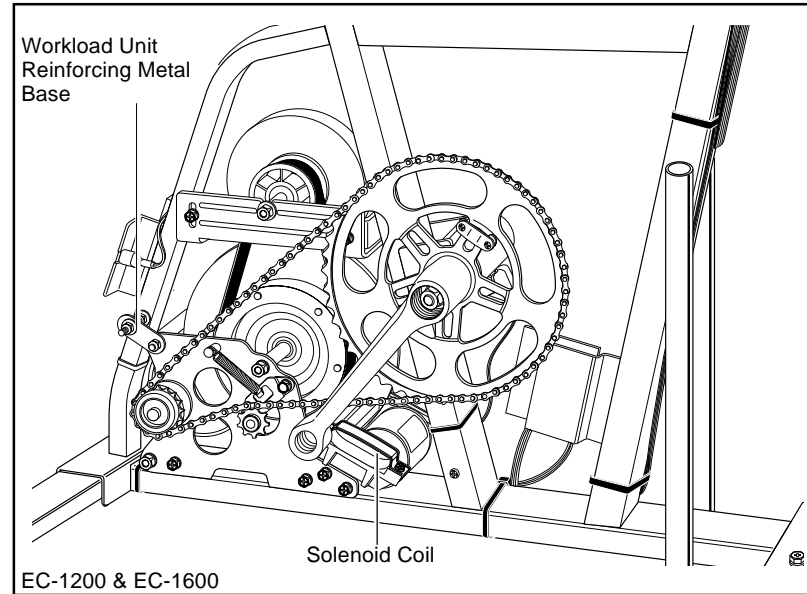

Fig. 1

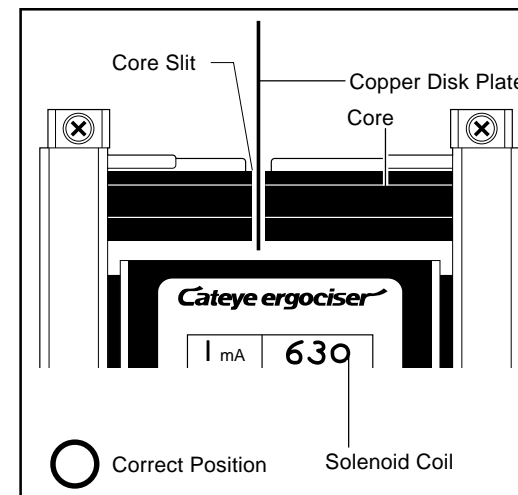

Fig. 2

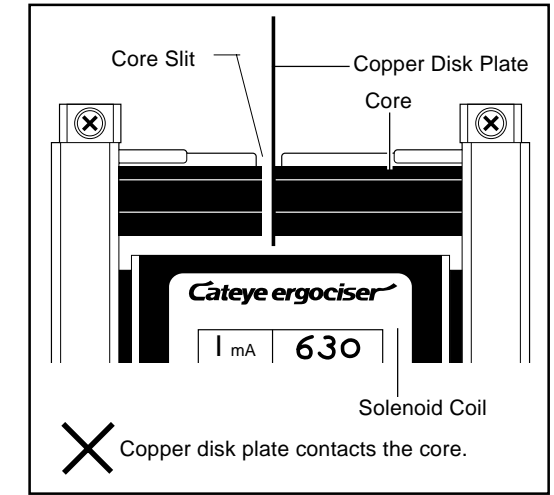

Fig. 3

ES-5 Replacing the CDC Sensor

1. Remove the frame cover. (See the Sections D-1 & D-2 "Removing the Frame Covers.")
2. Detach the CN-3 connector from the power supply board. (Fig. 1)
3. Cut the cable holders which fix the CDC sensor cable to the frame.
4. Remove the defective CDC sensor set by loosening the screws, and mount and fix the brandnew CDC sensor set. (Fig. 2)
5. Perform the following adjustments. (Figs. 3 and 4)
 - ⊙ Align the line on the CDC sensor with the center of the line on the CDC magnet. (Fig. 3)
 - ⊙ Adjust the gap between the surface of CDC sensor and the surface of CDC magnet to be approx. 2mm. (Fig. 4)
- * If the gap is inadequate, bend the metal base to secure the specified gap.
6. Securely connect the CN-3 connector to the power supply board. (Fig. 1)
7. Rotate the crank, and check if the pedal cadence will be displayed on the control unit.
8. Fix the CDC sensor cable to the frame by using cable holders. (Fig. 5)
9. Assemble the frame cover. (See the Sections D-1 & D-2 "Removing the Frame Covers.")

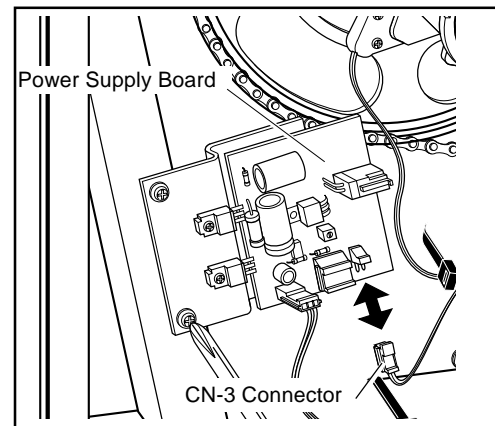
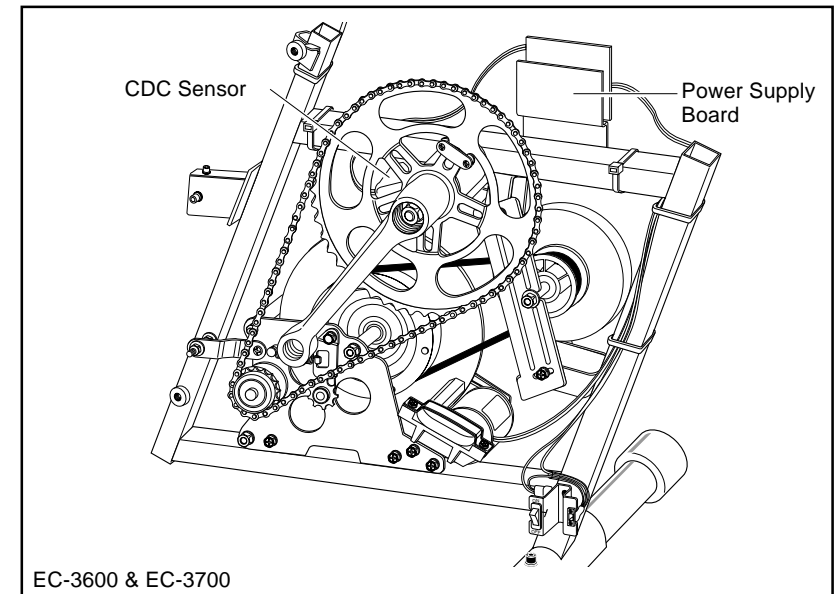
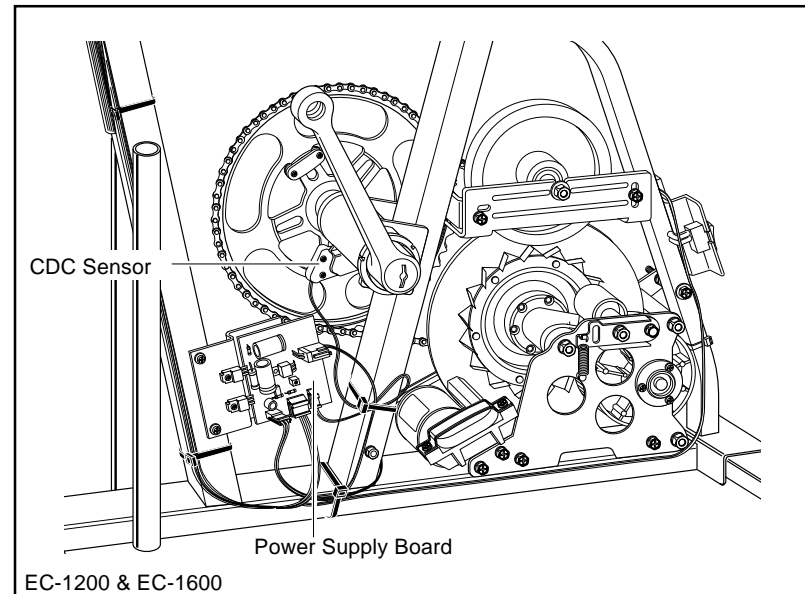

Fig. 1

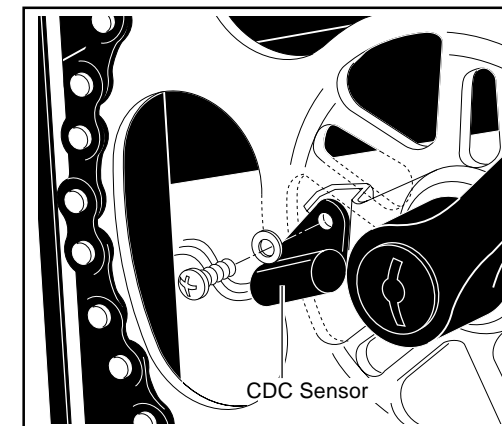

Fig. 2

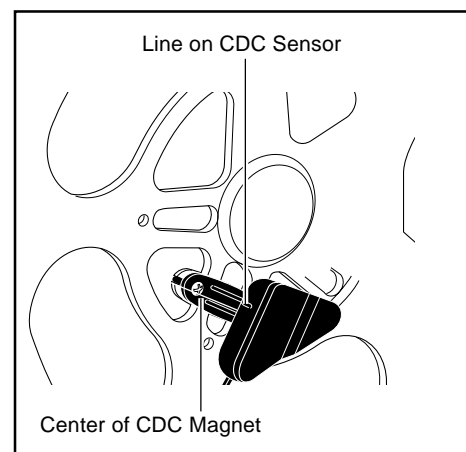

Fig. 3

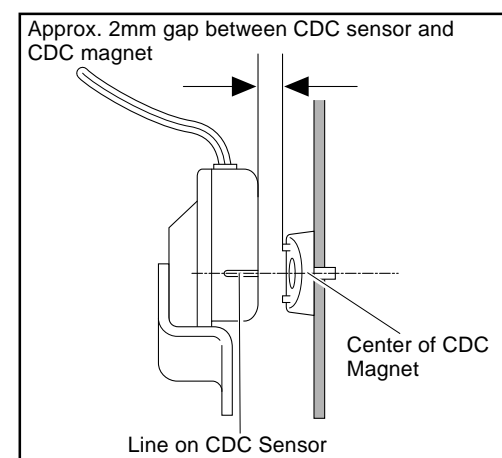

Fig. 4

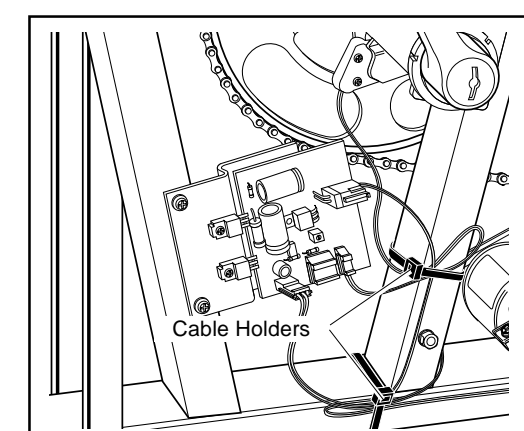

Fig. 5

ES-6 Replacing the Panel Keyboard

1. Remove the control unit by loosening four screws. Also remove the cable connector from the control unit. (Fig. 1)
2. The control unit can be separated into upper and lower parts when the eight screws on the bottom of the lower body of the unit are removed (Fig. 2). Be careful to separate them slowly since the upper and lower bodies are connected with a flat cable.
3. Remove the connector on the panel keyboard which is located at the upper body side, loosen the nine screws on the substrate, and remove them from the upper body. (Fig. 3)
4. Since the panel keyboard is fixed to the control unit with silicon, cut the silicon with a sharp cutter (Fig. 4). Peel the panel keyboard off the surface of upper body. (Fig. 5)
5. If the silicon remains at the upper body, remove it thoroughly.
6. Place the brandnew panel keyboard. The cable from the keyboard should be pulled in through the hole on the upper body. Press and adhere the panel keyboard in position.
7. Apply silicon at two depicted areas to prevent intrusion of sweat. (Figs. 4 and 6)
8. Mount the substrate and fix it with nine screws, and insert the connector of the panel keyboard. (Fig. 3)
9. Put the upper and lower body together, and fix them with eight screws.
10. Connect the cable connector to the control unit, and mount the unit to the main unit.

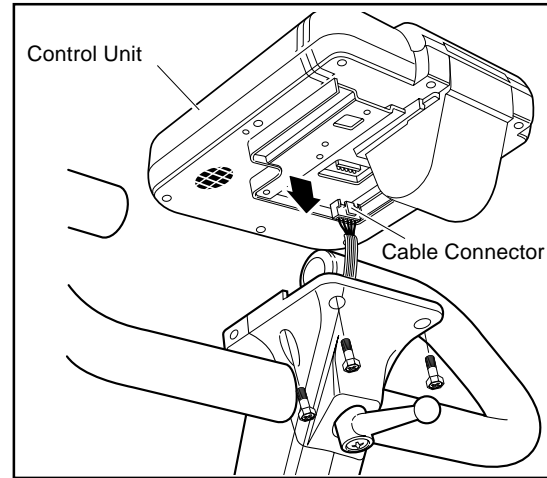

Fig. 1

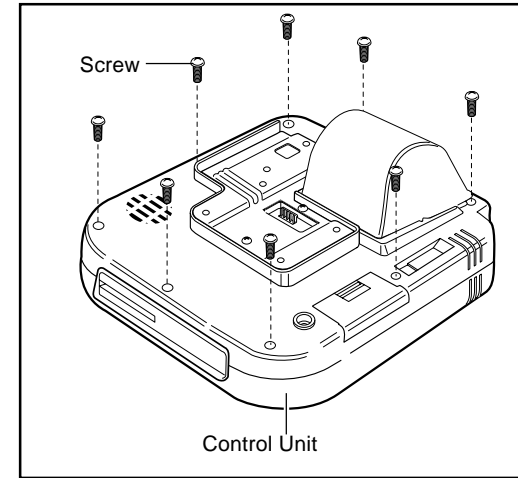

Fig. 2

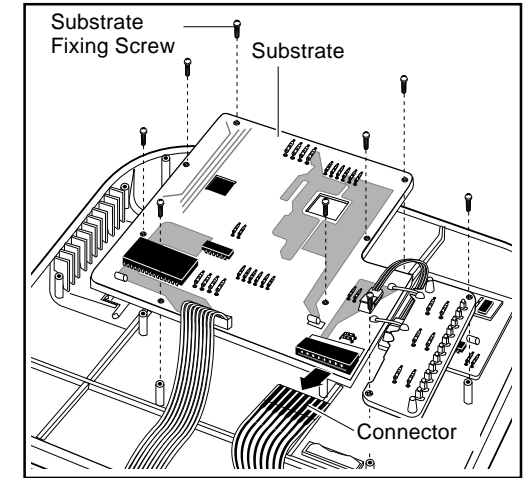

Fig. 3

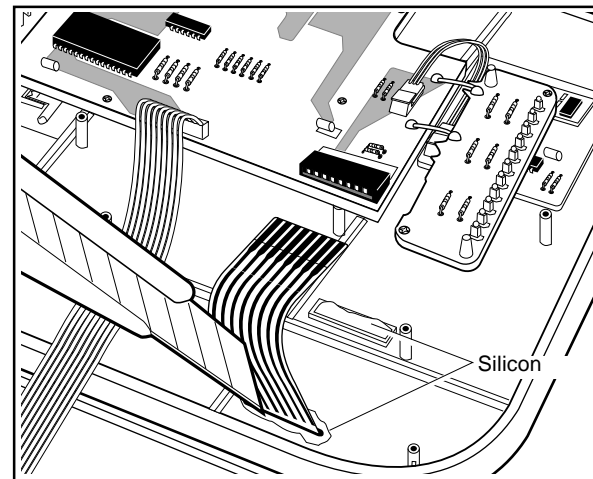

Fig. 4

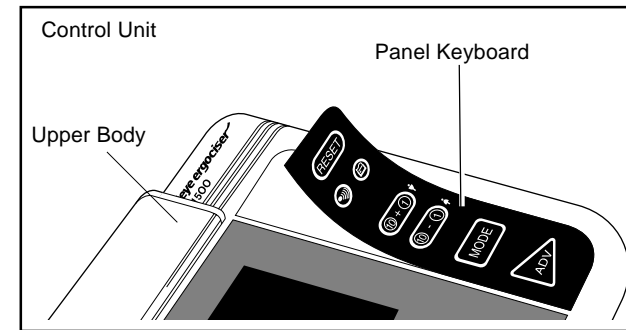

Fig. 5

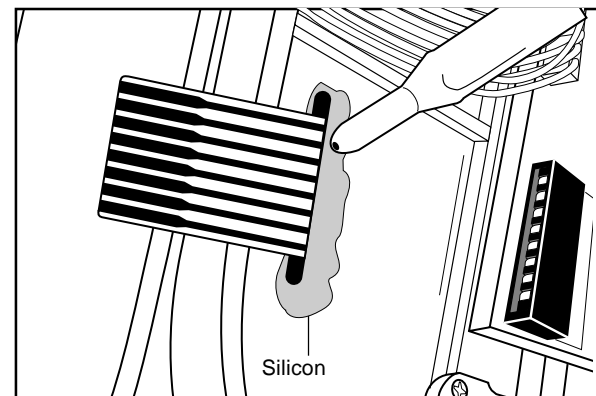

Fig. 6

ES-7 Replacing the Button Panel

1. Insert a thin cutting knife, while paying cautions not to damage the control unit, in between the button panel and the body, and carefully peel off the button panel. (Fig. 1)
 2. Clean the adhesive agent, if any, on the control unit before placing a brandnew button panel.
- * Sufficiently press the button panel thus placed.

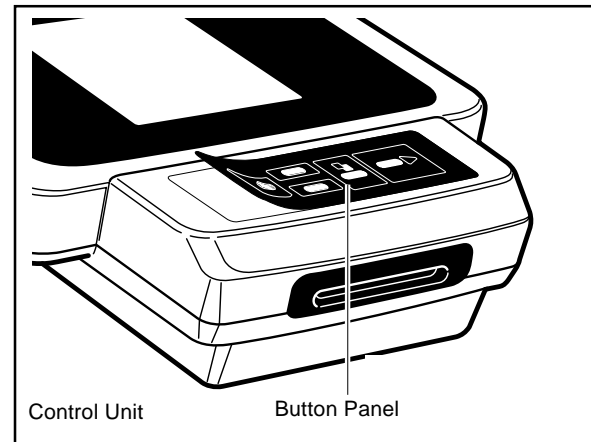

Fig. 1

ES-8 Replacing the Printer

1. Open the control unit into upper and lower bodies by referring to the Section ES-6 "Replacing the Panel Keyboard (1) & (2)."
2. unit is fixed to the lower body with two screws. Remove these two screws. (Fig. 1)
3. The printer unit can be removed after detaching cable connectors CN-2 and CN-3 of the printer unit. To remove the connector CN-3, just pull it, while to remove connector CN-2, the use of tweezers will be recommended. (Fig. 2)
4. Connect the connector CN-2 of the brandnew printer unit. Then, connect CN-3. For the connection, press it while moving it to right and left side alternatively.
5. Fix the printer unit with two screws. (Fig. 1)
6. Put the upper and lower bodies together, and fix them with eight screws.
7. Adjust the printing darkness by referring to the Section ES-9 "Adjusting the Printing Darkness."
8. Mount the control unit to the main unit.

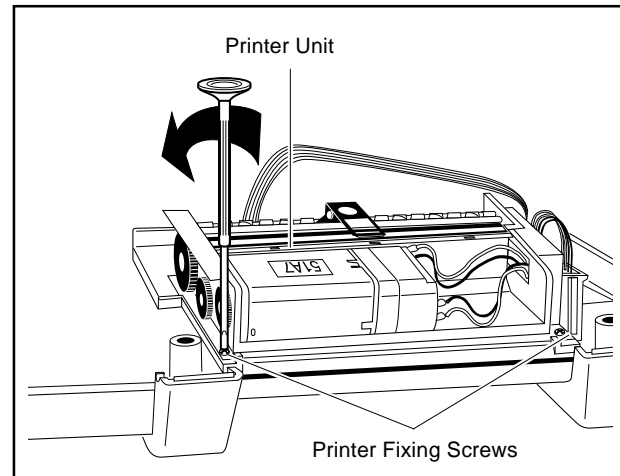

Fig. 1

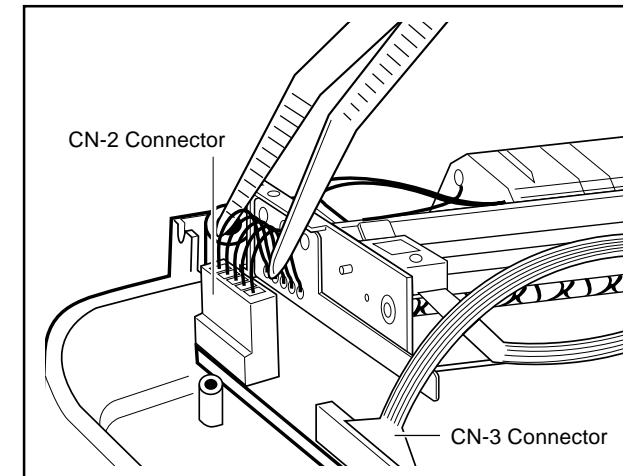

Fig. 2

ES-9 Adjusting the Printing Darkness

1. Remove the control unit from the main unit. (Fig. 1)
2. Loosen four screws on the bottom of the control unit, and remove the cable connector from the unit. (Fig. 1)
3. Remove the black metal base on the bottom of the control unit. (Fig. 2)
4. Provisionally connect the 5P connector on the bottom of the control unit to the main unit.
5. Turn on the power. Check if the printer symbol appears on the LCD panel and the printer is in the operating condition.
6. Check if the thermal paper is set in position.
7. Adjustment should be done with the control unit positioned horizontally. Press the ADV button on the control panel twice to perform a test printing. A counter-clockwise turn of the potentiometer PR on the bottom of the control unit will decrease the darkness, while a clockwise turn will increase it (Fig. 2). Set it to an appropriate darkness level. (An extreme clockwise turn of the potentiometer may distort the printed characters.)

NOTE: Never touch the potentiometer DCV.

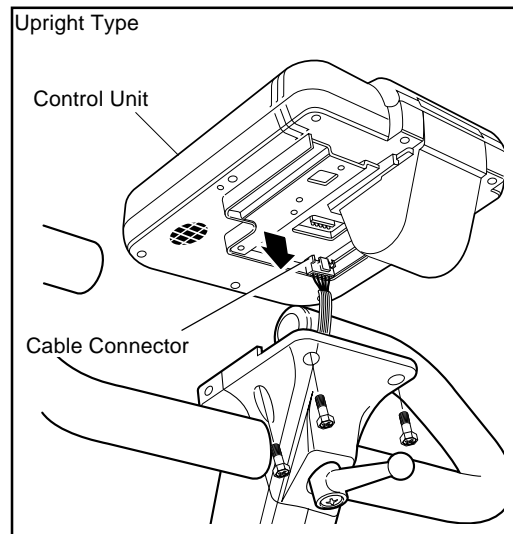

Fig. 1

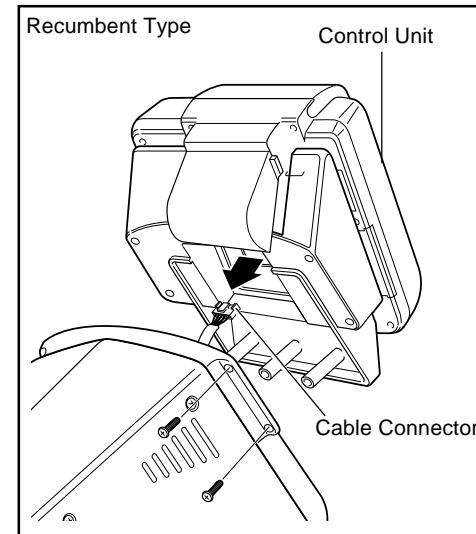

Fig. 2

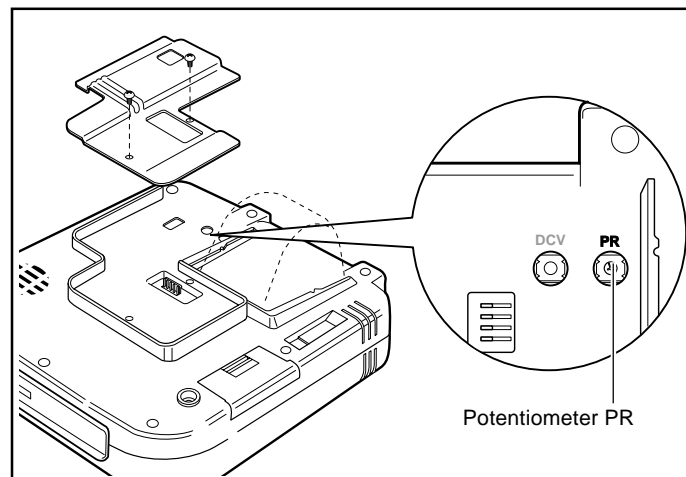

Fig. 3

ES-10 Paper Jamming in Printer

1. Open the control unit into upper and lower bodies by referring to the Section ES-6 "Replacing the Panel Keyboard (1) & (2)."
2. Remove the jammed paper with a tweezer or the like. (Fig. 1)
3. Assemble the control unit by referring to the Section ES-6 "Replacing the Panel Keyboard (9) & (10)."
4. Set the printer paper. (See the Operation Manual.)

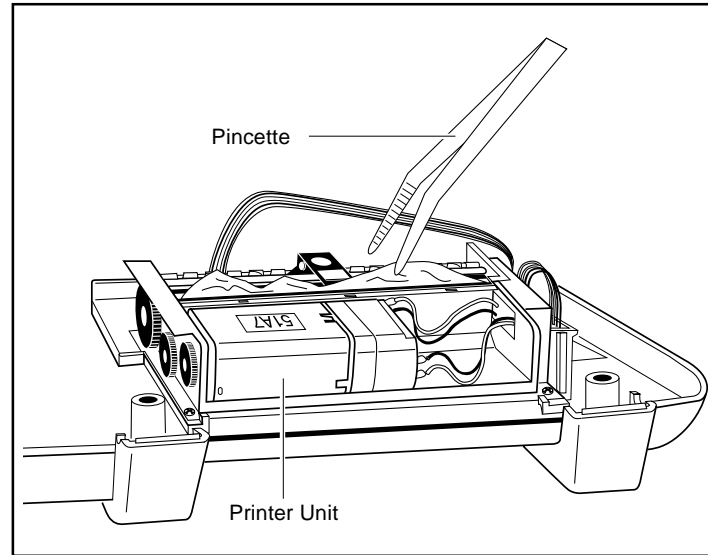

Fig. 1

MS-1 Replacing the Workload Unit (w/o Flywheel) (1)

■ Removing the Workload Unit

1. Remove the frame cover, by referring to the Sections D-1 & D-2 "Removing the Frame Covers."
2. Detach the CN-1 connector on the power supply board.
3. Using a nipper or the like, cut the cable holder which fixes the CN-1 connector, while paying attention not to damage the cable. (Fig. 2)
4. Remove the gear crank, by referring to the Section MS-8 "Replacing the Crank Set." Also, remove the chain together with the gear crank.
5. Using a wrench, loosen the nuts, which fix the workload unit reinforcing metal base, on both the workload unit side and the frame side, and remove the metal base. (Fig. 3)
6. Remove the hexagon head bolts which fix the workload unit (two bolts on either right and left sides). Lift the entire workload unit upward until it comes off the workload unit fixing metal base, and remove the unit by shifting it either in the right or left side (Fig. 4). Be careful that the copper disk plate does not touch the frame.

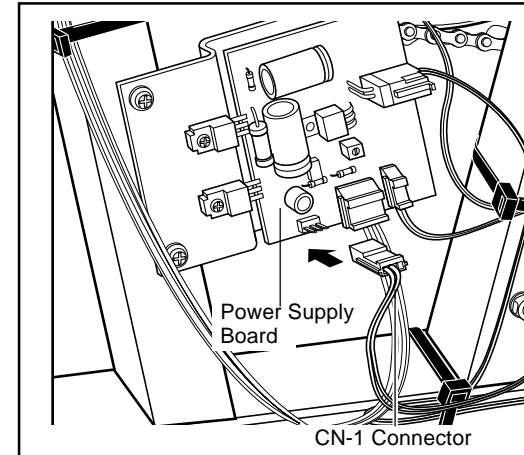
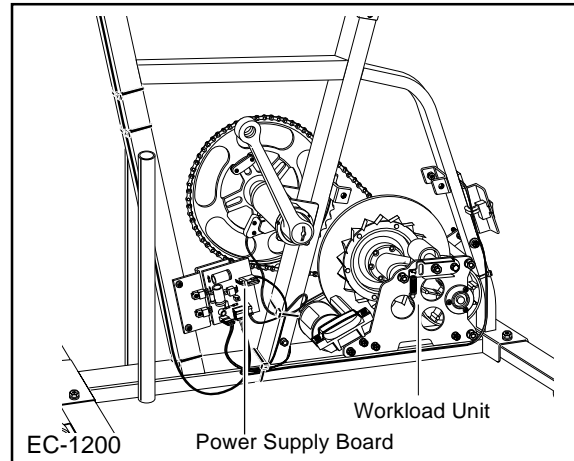

Fig. 1

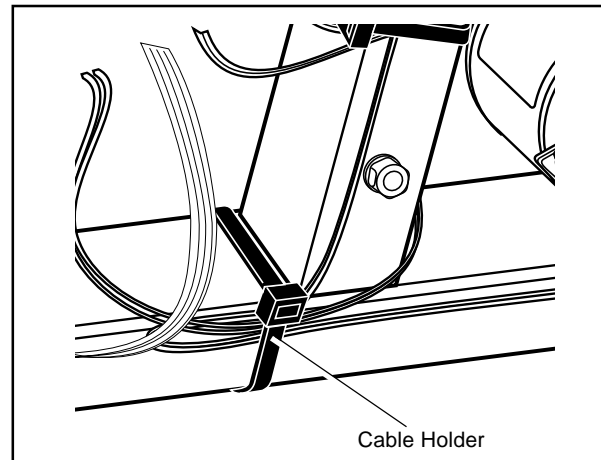

Fig. 2

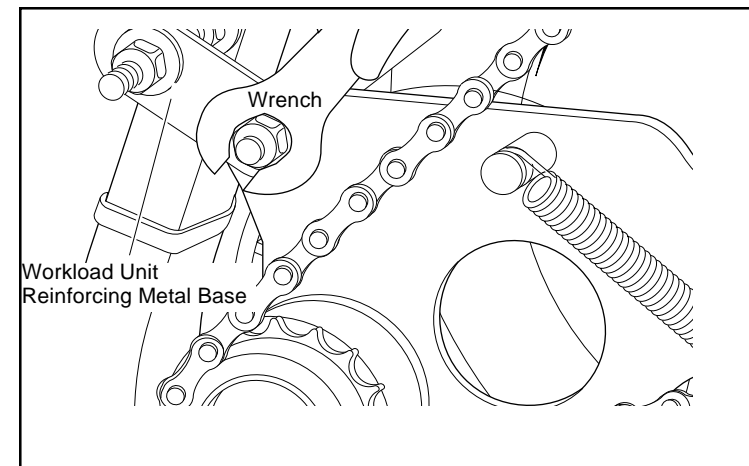

Fig. 3

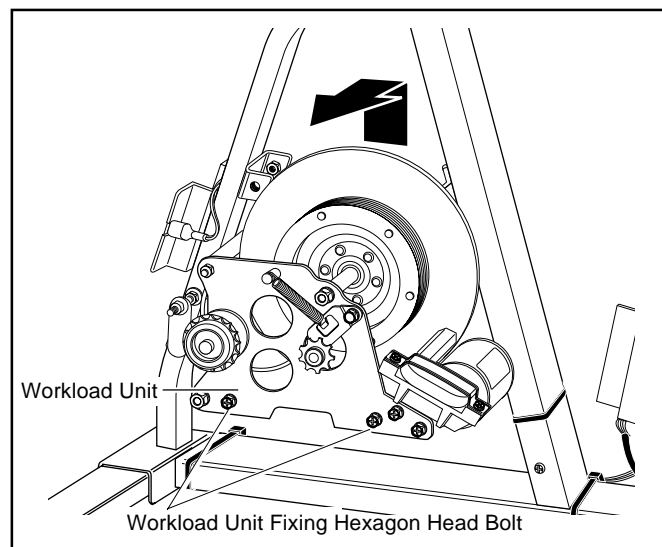

Fig. 4

MS-1 Replacing the Workload Unit (w/o Flywheel) (2)

■ Mounting the Brandnew Workload Unit

1. Assemble the brandnew workload unit so that it will engage with the workload unit mounting metal base of the frame (Fig. 1). Be careful that the copper disk plate will not touch the frame.
 2. Tighten the crank nut by using a cotterless gear crank removing/ fastening tool and a wrench (Figs. 2 and 3). Tightening torque should be 350kg cm to 400kg-cm, and tighten the nut until the end of the crank shaft can level with the end surface of the nut. Then, put the crank cap with a coin or the like. (Fig. 4)
 3. Assemble the chain. Chain should first be set on the free wheel before setting it to the upper part of the large gear. Then, a forward rotation of the crank will enable the complete setting on the large gear. (Fig. 5)
 4. Set the derailleur spring to the pawl of the derailleur to give tension to the chain. (Fig. 6)
 5. Adjust the position of the workload unit so that the tension of the chain at the workload unit can be adequate. Move the workload unit back and forth so that the longer edge of the derailleur fixing metal base can be positioned at a right angle to the derailleur spring. (Fig. 6)
 6. Tighten the workload unit fixing screw (two screws on either right and left sides). (Fig. 7) The tightening torque is 90kg-cm to 120kg-cm.
 7. Assemble the workload reinforcing metal base in between the bolts at the workload side and the frame side, and tighten the bolts with nuts. (Fig. 8)
- * In case the nut is screwed in at the position where the workload-unit-side workload unit metal base is supposed to be mounted, remove the nut.
- * The tightening torque at the workload unit side should be 90kg-cm to 120kg-cm, and the nut at the frame side should be provisionally tightened.

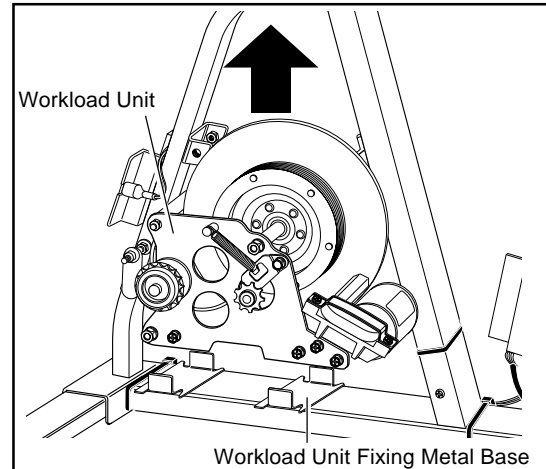

Fig. 1

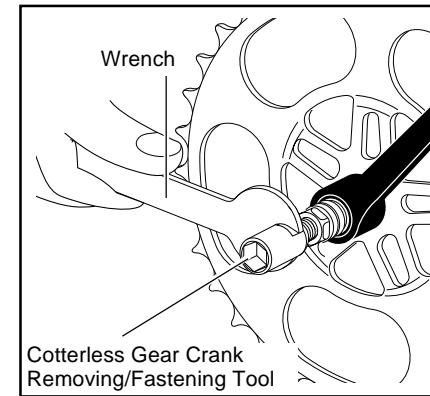

Fig. 2

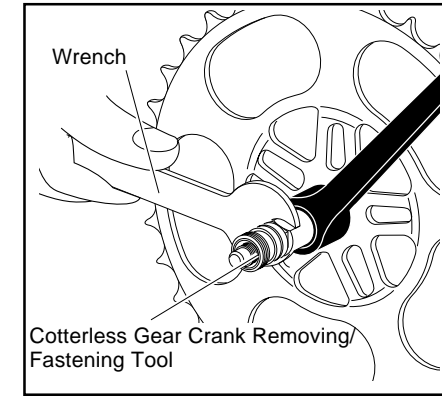

Fig. 3

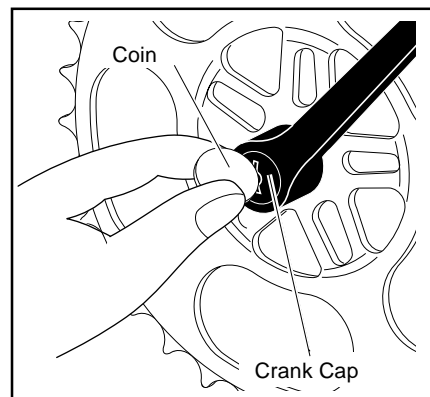

Fig. 4

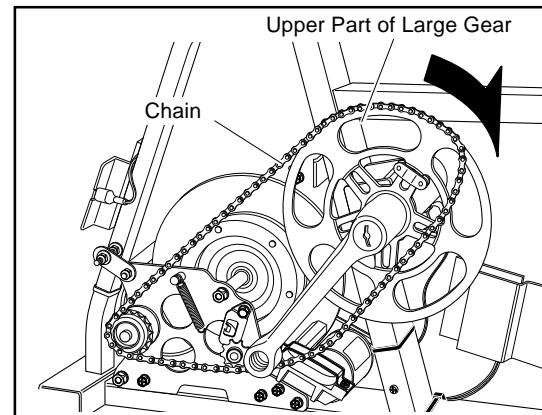

Fig. 5

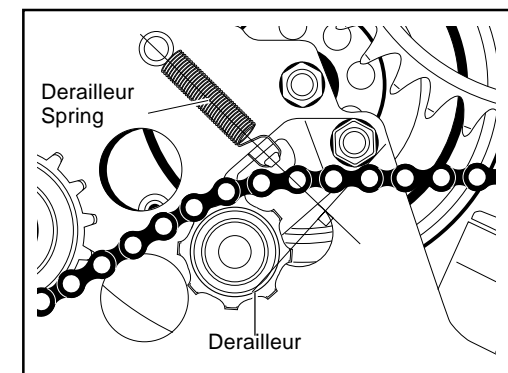

Fig. 6

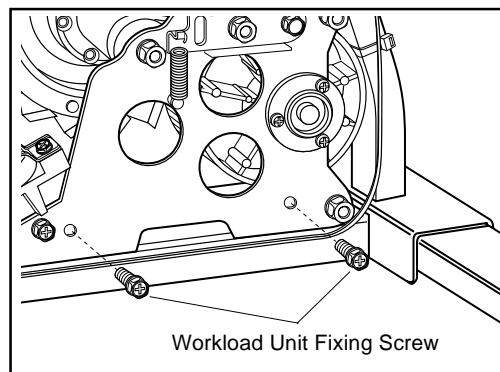

Fig. 7

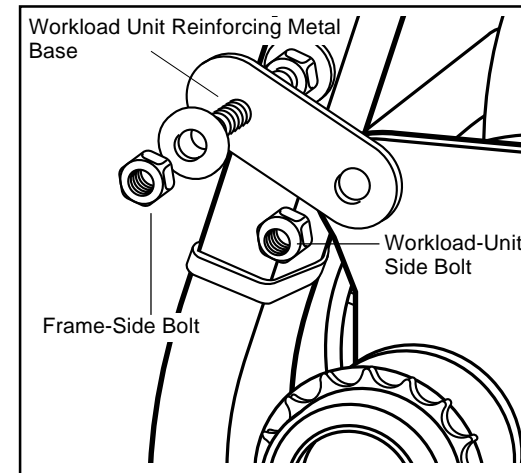

Fig. 8

MS-1 Replacing the Workload Unit (w/o Flywheel) (3)

■ Checking the Positions of Copper Disk Plate and Solenoid Coil Core Slit

- ◎ Regarding the workload unit, positions of copper disk plate and solenoid coil core slit have been adjusted before mounting the frame so that they will not touch each other while the plate is rotating. However, due to positional distortion caused by tightening the bolts while the frame is being mounted, the copper disk plate may touch the core. (Fig. 1)
- ◎ Rotate the copper disk plate slowly to check if it does not touch the core. If it does, it is necessary to eliminate the positional distortion caused by the tightening.

Correction Method

Correction can be made by tightening the frame-side nuts of the workload reinforcing metal base. Tighten the metal base toward the direction in which the positional correction of the copper disk plate should be made, until the plate comes close to the center of the core slit (Fig. 1). (See the Section ES-4 "Correcting the Position of Solenoid Coil.")

1. After checking the correction direction, use a wrench to tighten the frame-side nut of the workload unit reinforcing metal base. Give the even tightening to both right and left sides.
2. As shown in Fig. 2, set a cable for measuring coil current in between the CN-1 female connector and the CN-1 male connector at the side of power supply board, and connect the cable to an ammeter.
3. Turn on the power switch of the main unit, set the control unit to the manual mode, select the torque at 4.0kg-m, and start the system.
4. Using a blade-head screwdriver, adjust the potentiometer on the power supply board so that the meter reading shows the coil current which is specified on the solenoid coil of the workload unit.

Example: As shown in Fig. 3, when 630 is indicated, adjust the potentiometer so that the coil current will be 630mA.
5. After having adjusted the coil current, remove the measuring cable, and connect the female connector of the CN-1 cable directly to the male connector at the power supply board side.
6. Fix the cable onto the seat pipe with cable holders.

■ Adjusting the Flywheel

1. Adjust the flywheel by referring to the Section MS-3 "Adjusting the Flywheel."

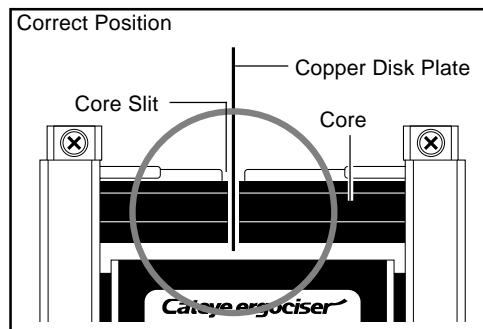

Fig. 1

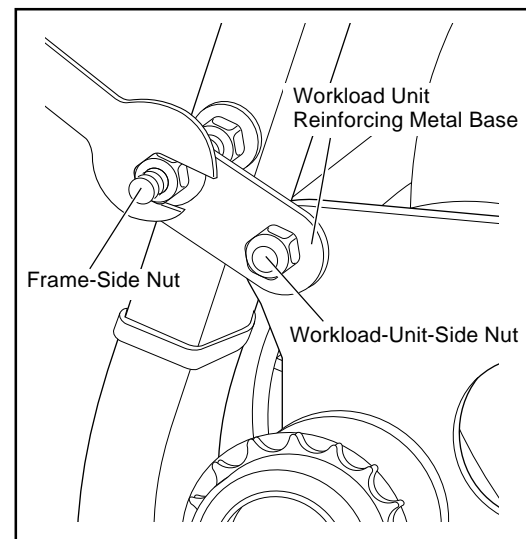

Fig. 2

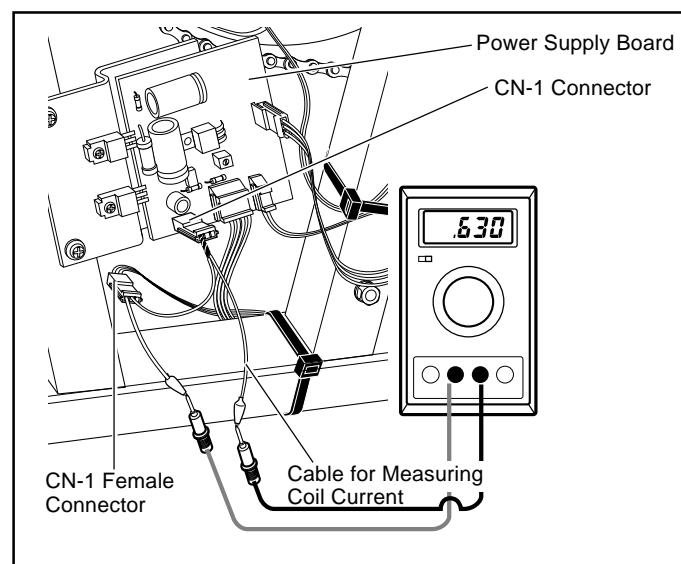

Fig. 3

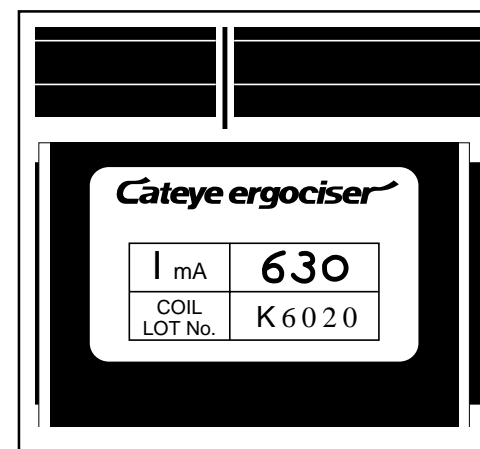

Fig. 4

MS-2 Replacing the Workload Unit (w/ Flywheel)

■ Removing the Workload Unit

1. Remove the gear crank and the chain by referring to Items 1 through 4 of the Section MS-1 "Replacing the Workload Unit (w/o Flywheel) (1)."
2. Loosen the flywheel fixing nut which is fixed to the flywheel metal base. (Fig. 1)
3. Remove the four bolts which fix the flywheel metal base, and remove the plain belt. (Fig. 2)
4. Remove the workload unit by referring to Items 5 and 6 of the Section MS-1 "Replacing the Workload Unit (w/o flywheel) (1)."

■ Mounting the Brandnew Workload Unit

1. Assemble the brandnew workload unit so that it will engage with the workload unit mounting metal base of the frame (Fig. 1). [See the Item 1 of the Section MS-1 "Replacing the Workload Unit (w/o flywheel) (2)."]
2. Hang the plain belt on the flywheel, and fix it to the flywheel metal base with the flywheel fixing nut.
3. Provisionally fasten the metal base fixing screw (4 pieces) to the flywheel fixing metal base and the frame respectively. (Fig. 2)
4. Mount the workload unit by referring to Items 2 to 6 of the Section MS-1 "Replacing the Workload Unit (w/o flywheel) (2)."

■ Adjusting the Flywheel

1. Adjust the flywheel by referring to the Section MS-3 "Adjusting the Flywheel."

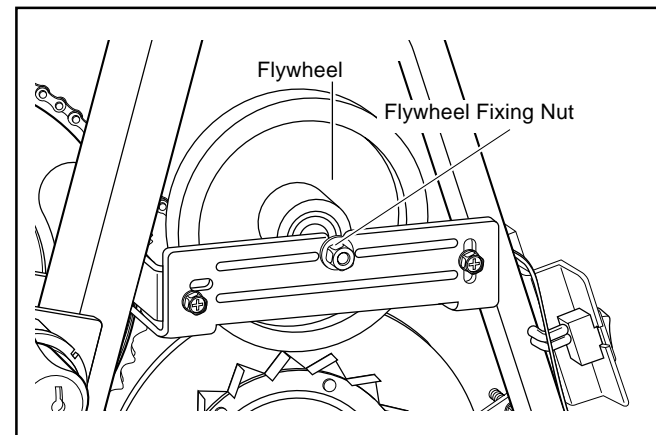
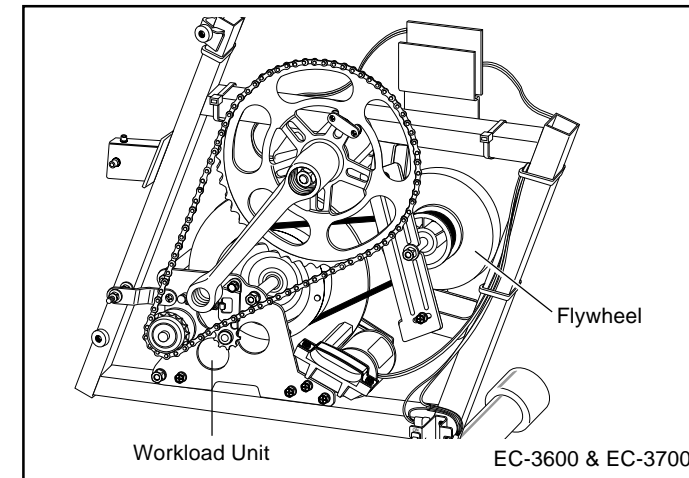
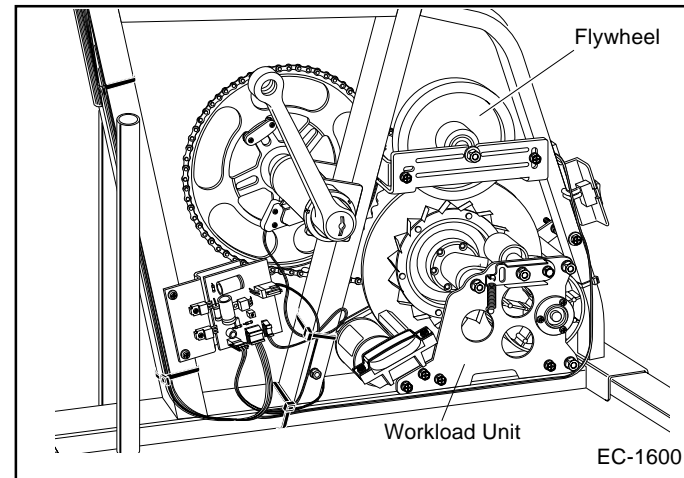

Fig. 1

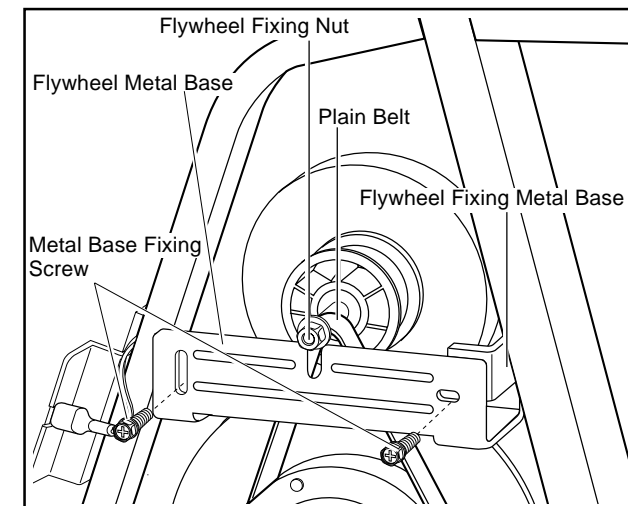

Fig. 2

MS-3 Adjusting the Flywheel

■ Adjustment Method of Flywheel

Since the plain belt which delivers the rotation of both the workload unit and flywheel requires an adequate tension, a specified tension should be given to the plain belt in the following adjustment procedures. For this adjustment, use commercial tools, since no purpose-designed tool is not prepared.

1. Set a commercial wire around the flywheel metal base as depicted in Fig. 1, and tie up the both ends outside the frame.
2. Hang a commercial spring scale at the top of the wire thus tied up, and lift the scale upward with a pulling force of 5 to 6 kg.
3. Keeping this status, fully tighten the four metal base fixing screws which had been fastened provisionally. (Fig. 2)

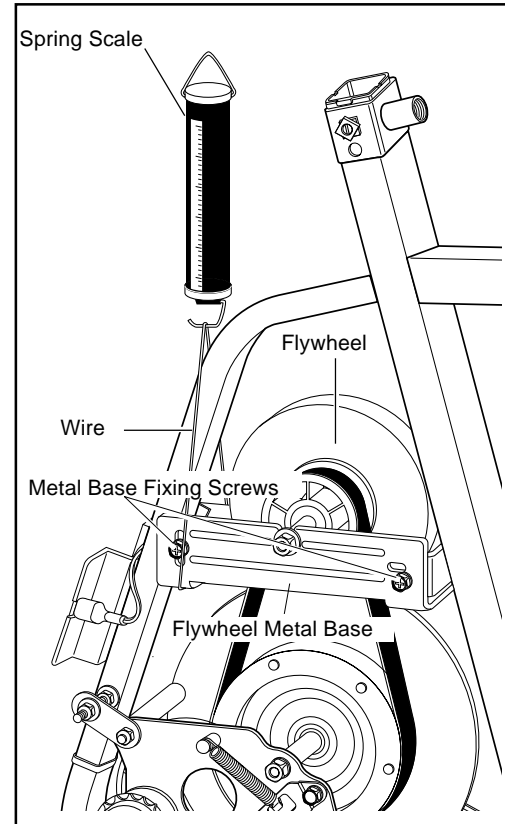

Fig. 1

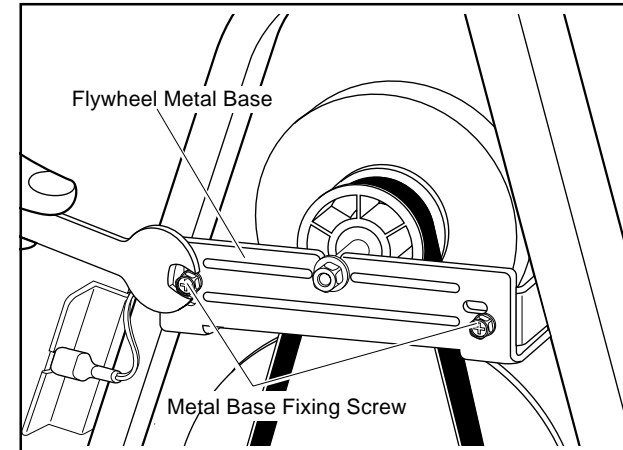

Fig. 2

MS-4 Replacing the Chain

1. Remove the frame cover by referring to the Sections D-1 & D-2 "Removing the Frame Covers."
 2. Use a screwdriver or the like to remove the derailleur spring which is hung on the derailleur metal base, thus loosening the chain.
 3. First detach the chain at the upper part of the large gear, and then rotate the crank forward to detach the entire chain. (Fig. 2)
 4. The brandnew chain should be hung firstly on the free wheel, and then hang it over the upper part of the large gear. A forward rotation of the crank will allow complete setting of the entire chain. (Fig. 3)
 5. Adjust the tension of chain. Hang the spring on the derailleur, loosen the workload fixing screw, and adjust the tension while sliding the workload unit back and forth. (Fig. 4)
- * Be careful not to give excessive tension to the chain.
6. Assemble the frame cover by referring to the Sections D-1 & D-2 "Removing the Frame Covers."

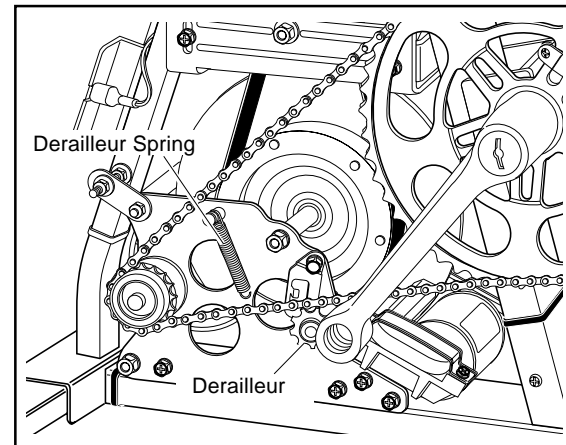
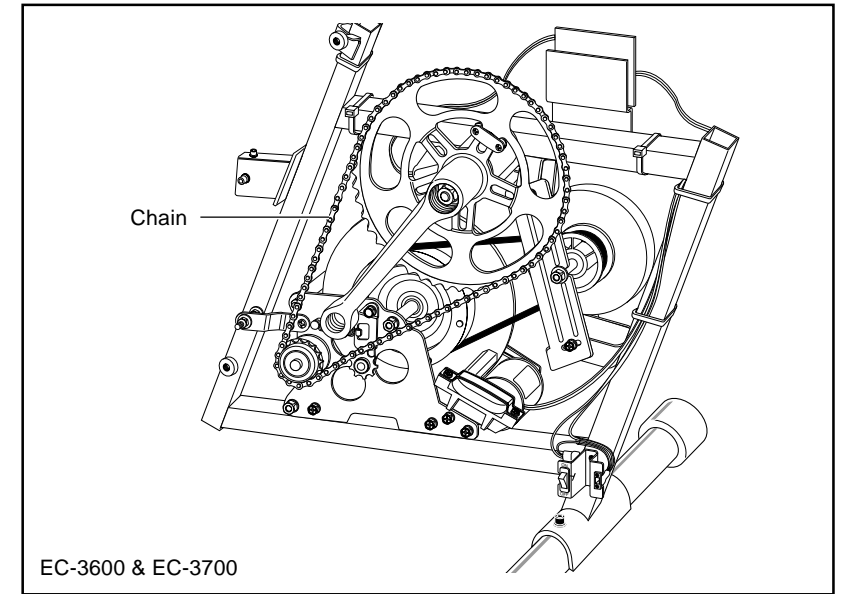
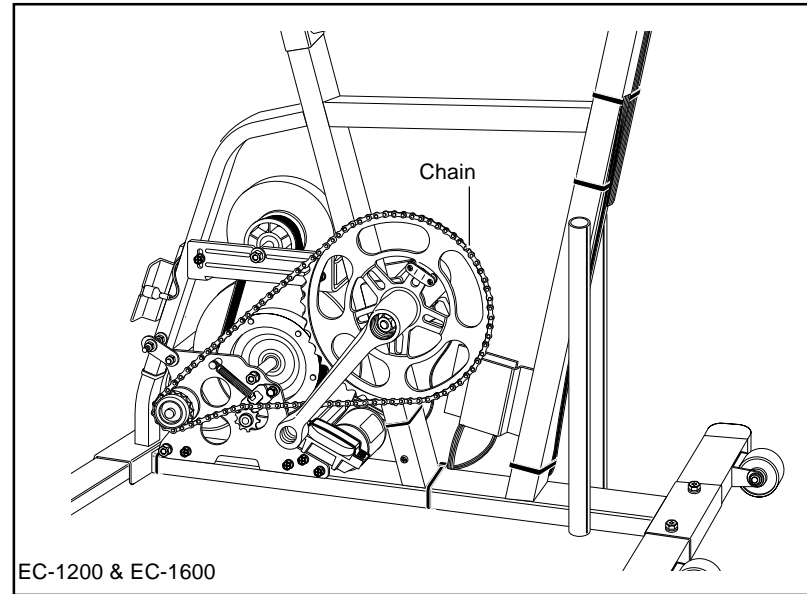

Fig. 1

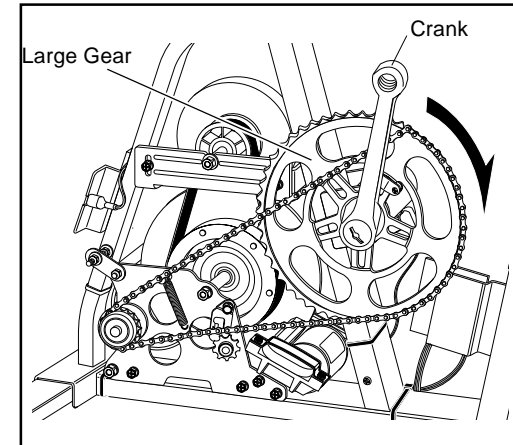

Fig. 2

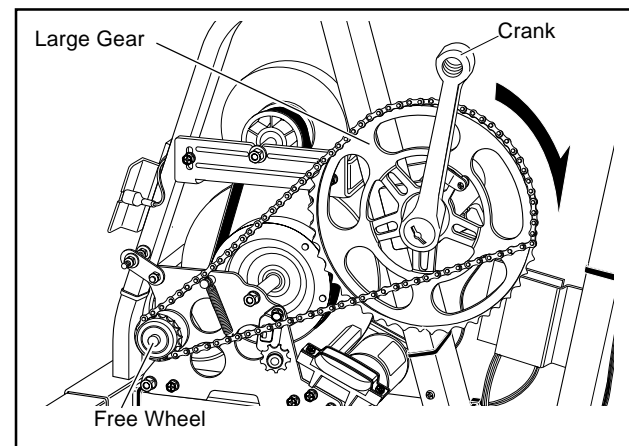

Fig. 3

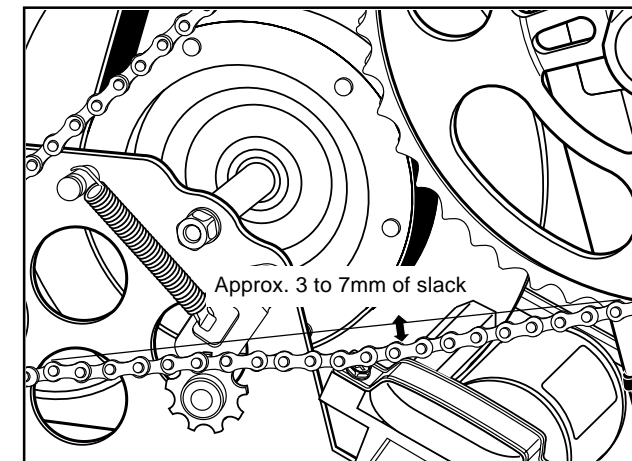

Fig. 4

MS-5 Replacing the Free Wheel Set

1. Detach the chain. (See the Section MS-4 "Replacing the Chain.")
2. Hold the D-cut section on the free wheel shaft with a No.13 wrench, and remove the hexagon U-nut. Then, pull off the free wheel set by using a free wheel remover. (Figs. 1 & 2)
3. Mount the brandnew free wheel set, and firmly tighten the hexagon nut. Tightening should be done while holding the D-cut section with a No.13 wrench. (Fig. 1)
4. Set the chain by referring to the Section MS-4 "Replacing the Chain."

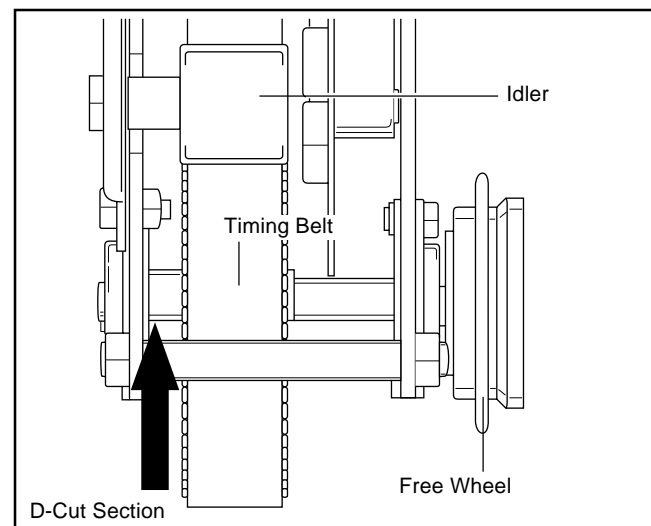
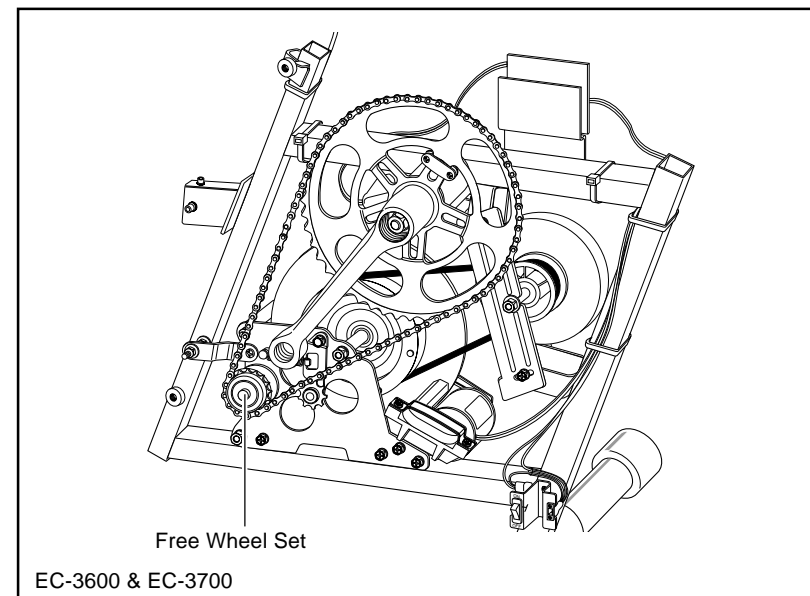
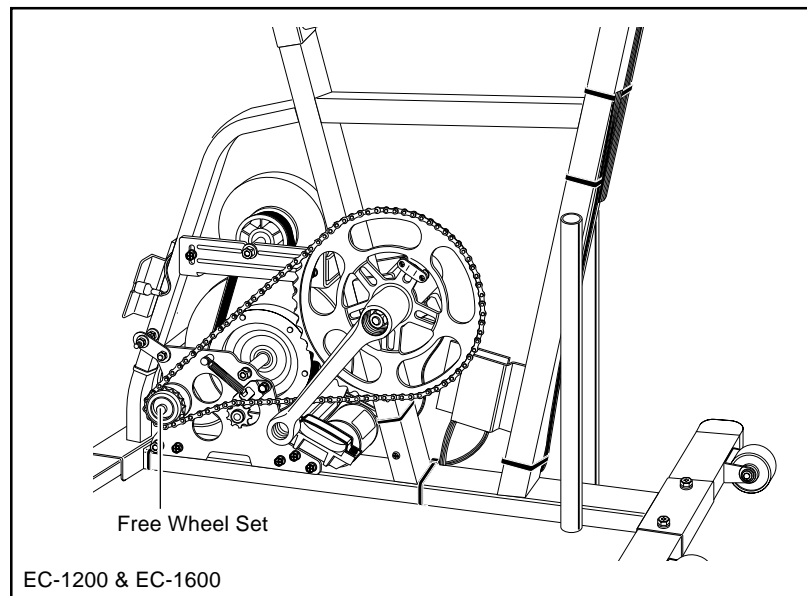

Fig. 1

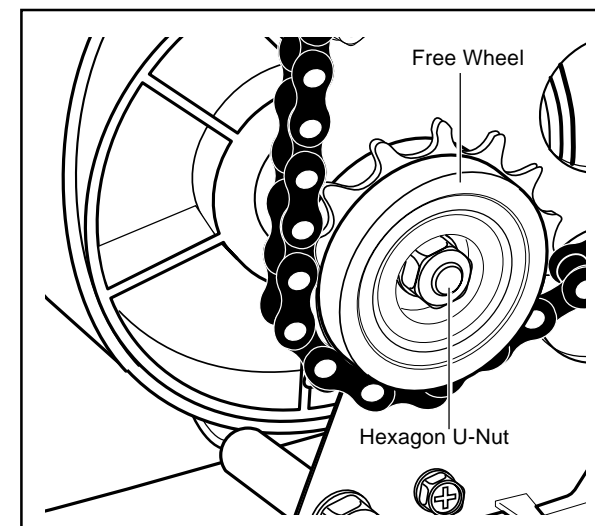

Fig. 2

MS-6 Replacing the Derailleur Set

1. Detach the derailleur spring from the pawl of the derailleur metal base. (Fig. 1)
2. Loosen the derailleur fixing bolt with a No.10 socket wrench, and remove the derailleur set. (Fig. 2)
3. Mount the brandnew derailleur set with fixing screws.
4. Set the derailleur spring on the pawl of the metal base to give tension to the chain.

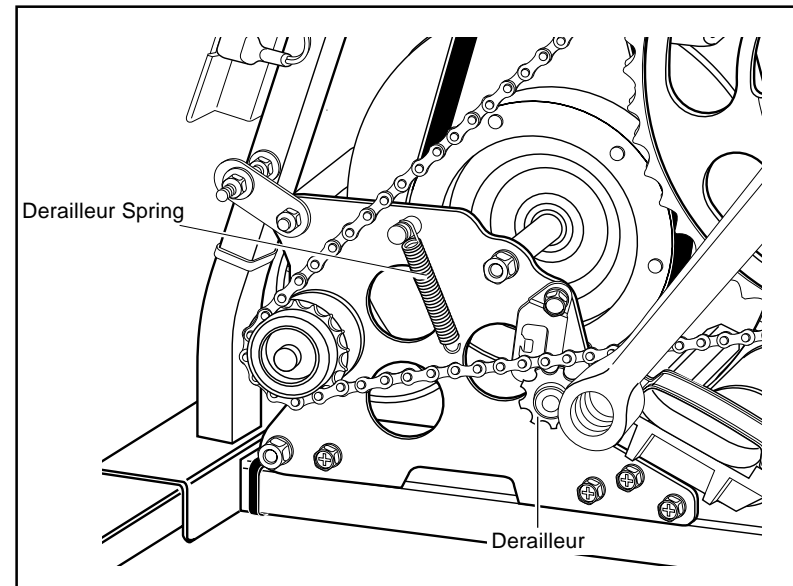
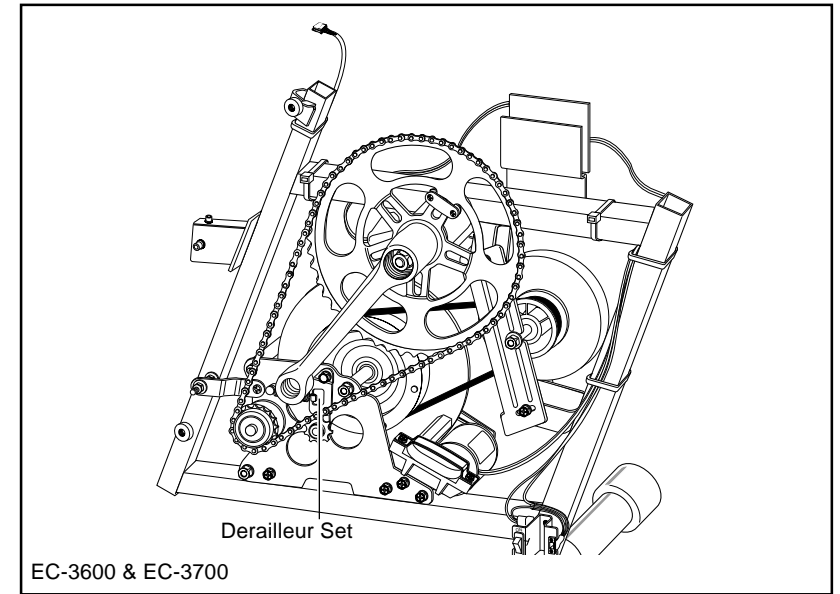
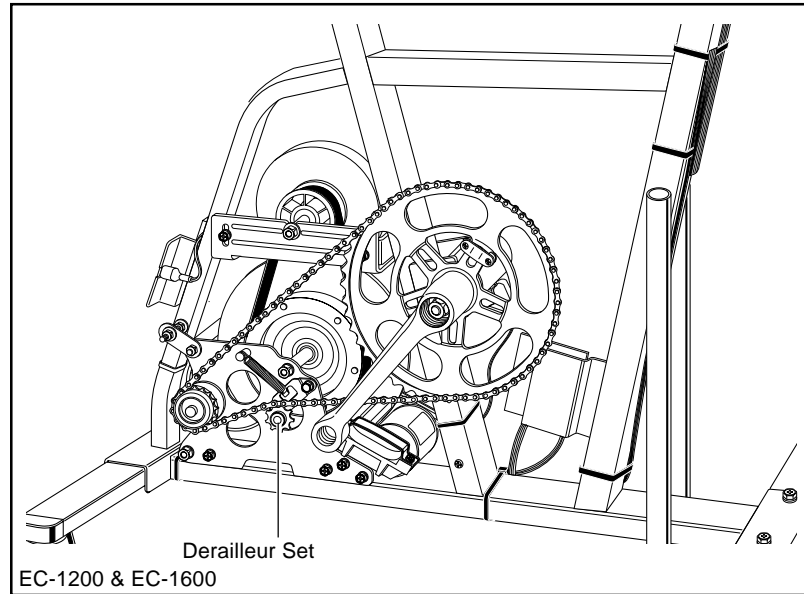

Fig. 1

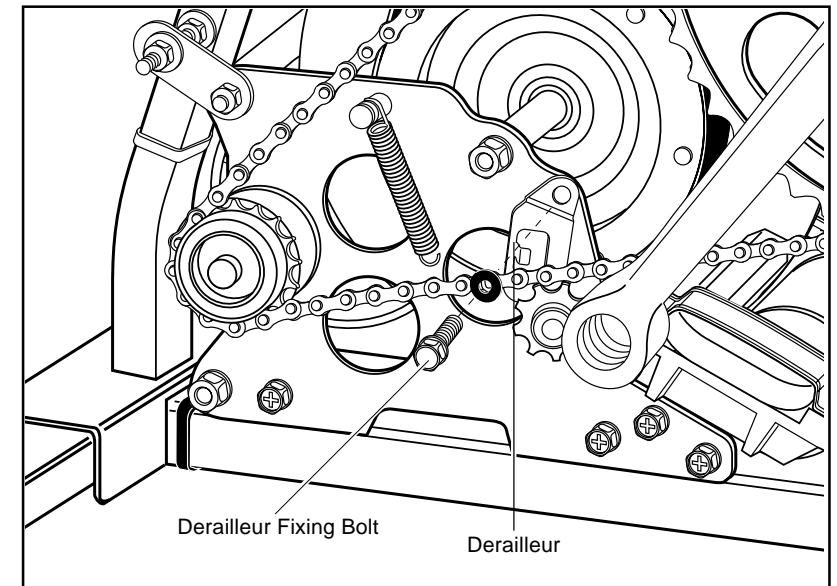

Fig. 2

MS-7 Replacing the Idler Set

1. Remove the frame cover by referring to the Sections D-1 & D-2 "Removing the Frame Covers."
2. Remove the idler spring from the pawl of the idler metal base. (Fig. 1)
3. Loosen the idler mounting bolts, and detach the idler set. (Fig. 2)
4. Mount a brandnew idler set by using an idler mounting bolt.
5. Hang the idler spring on the pawl of the idler to give tension to the belt.

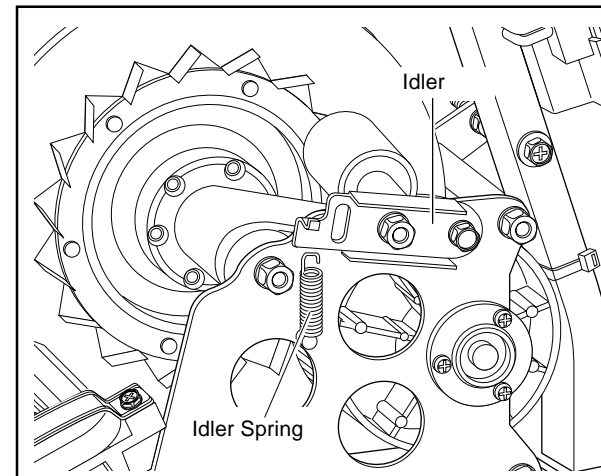
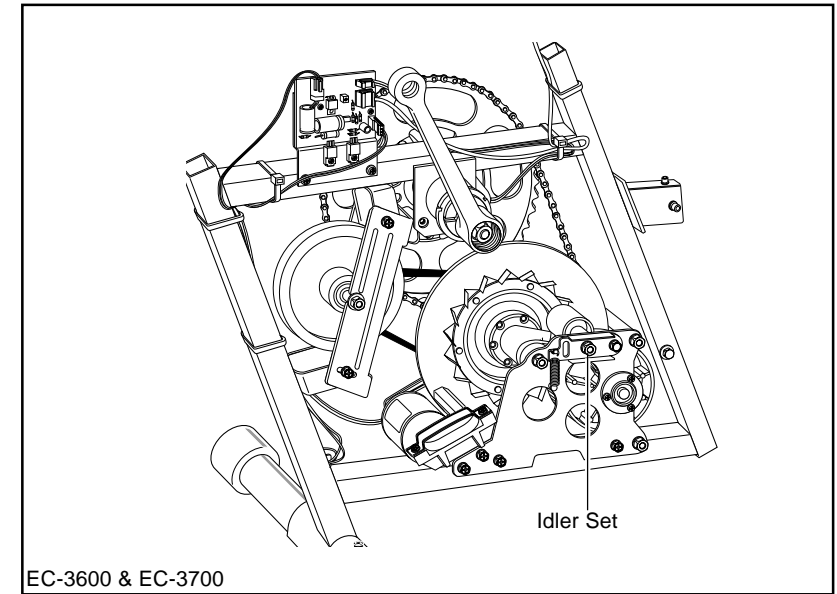
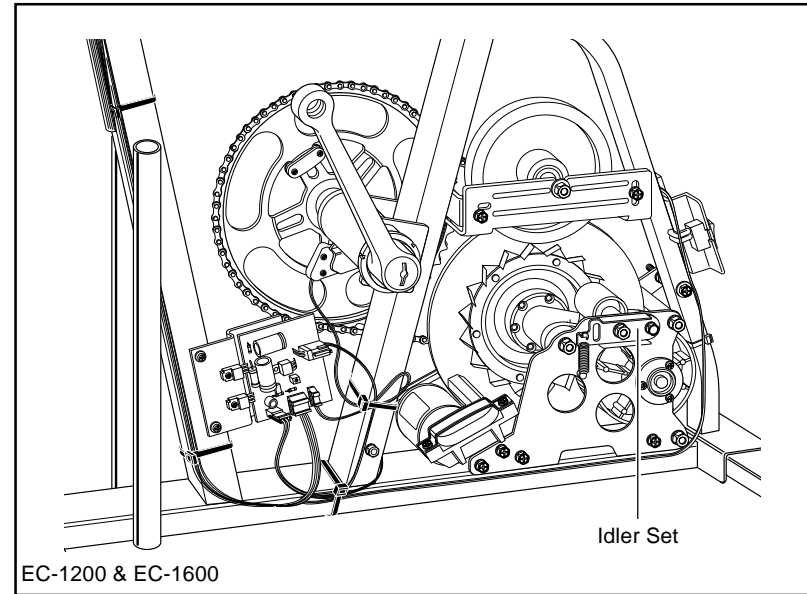

Fig. 1

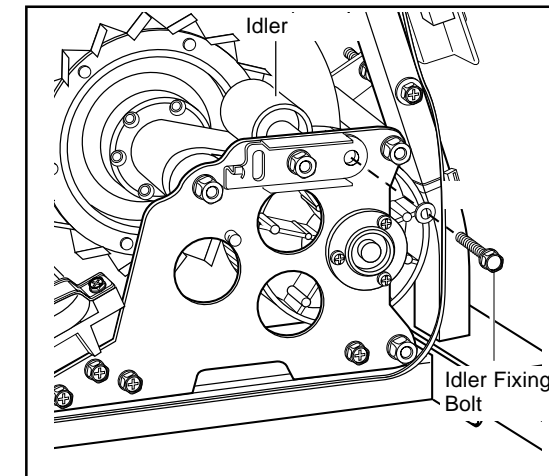

Fig. 2

MS-8 Replacing the Crank Set (1)

■ Removing the Gear Crank (Crank)

1. Remove the frame cover by referring to the Sections D-1 & D-2 "Removing the Frame Covers."
2. Detach the chain by referring to the Section MS-4 "Replacing the Chain." (Fig. 1)
3. Detach the crank cap with a coin or the like. (Fig. 2)
4. Use a cotterless gear crank removing/fastening tool and a wrench, rotate the crank nut to remove it. (Fig. 3)
5. Change the sides of a cotterless gear crank removing/fastening tool, and rotate it clockwise to remove the gear crank (crank) from the crank shaft. (Fig. 4)

- to be continued to the next page -

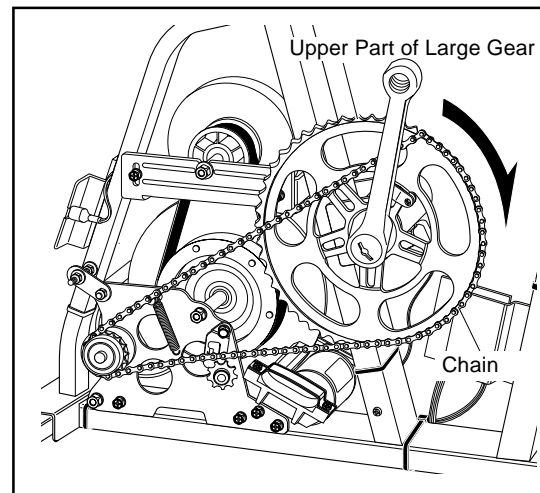
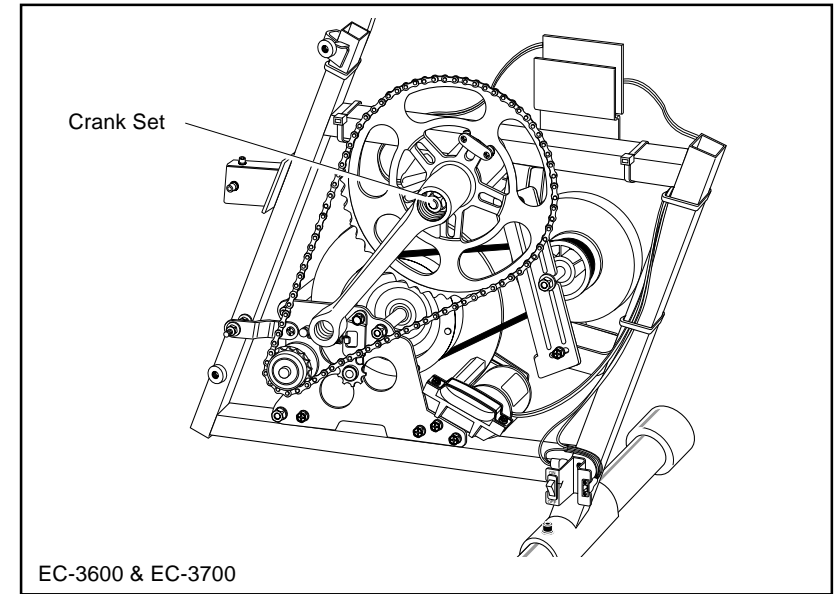
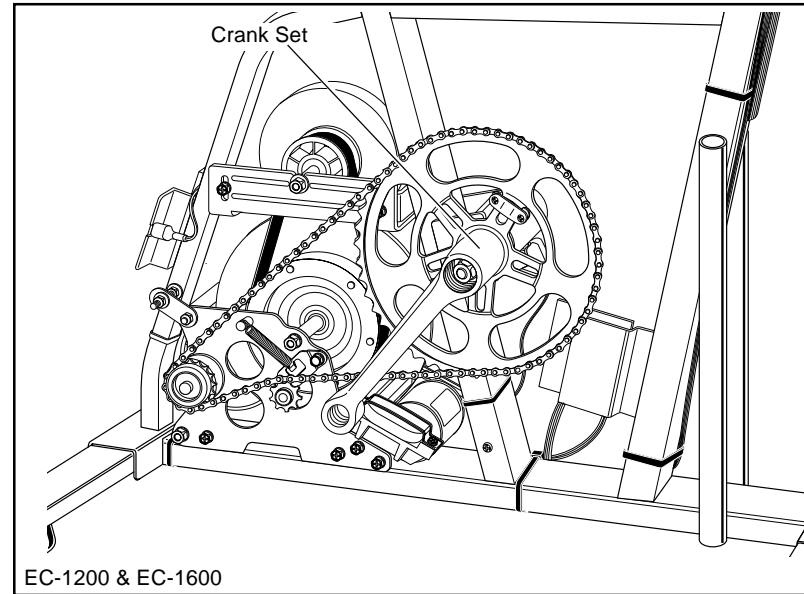

Fig. 1

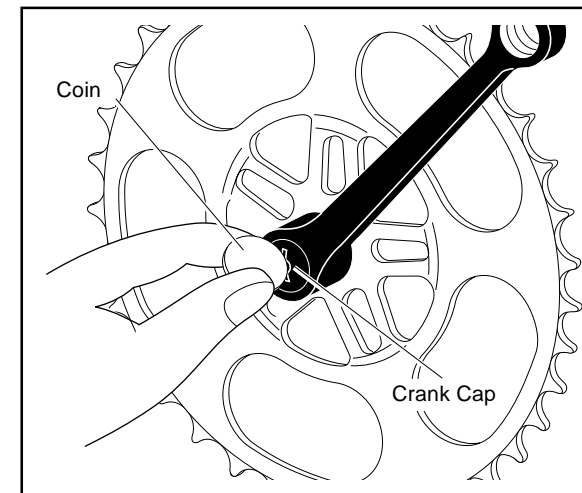

Fig. 2

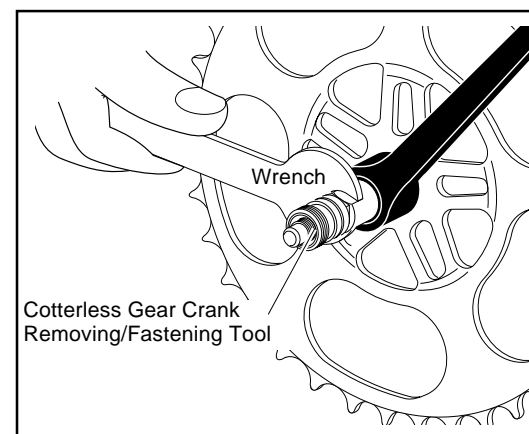

Fig. 3

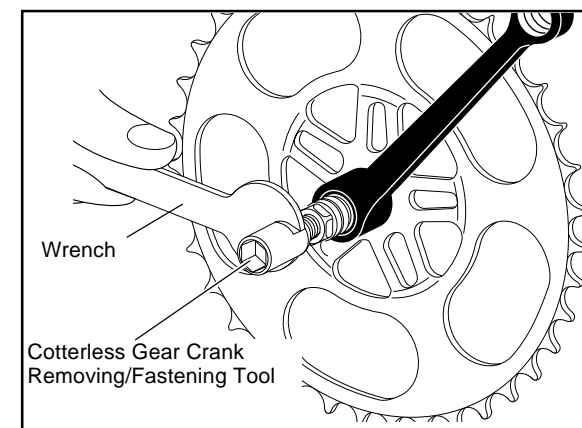

Fig. 4

MS-8 Replacing the Crank Set (2)

■ Assembling the Gear Crank (Crank)

1. Mount the gear crank (crank) to the crank shaft.
2. Securely fasten the crank nut by using a socket wrench (or by a cotterless gear crank removing/fastening tool and a wrench). (Figs. 1 & 2)
 - * Respective cranks should be positioned each other to from an angle of 180° against the gear. (Fig.3)
3. Fasten the crank cap by using a coin, etc. (Fig. 4)
4. The chain should be first set on the free wheel, and then on the upper part of the large gear. A forward rotation of the crank will enable the complete setting of the gear. (Fig. 5)
5. Adjust the tension of chain. Loosen the workload fixing screw [two screws at each right and left side (Fig. 6)], and adjust the tension while sliding the workload unit. The tension of chain should be adjusted as illustrated in Fig. 7.
 - * Be careful not to give excessive tensioning to the chain.
6. Adjust the clearance between the magnet mounted on the large gear and the CDC sensor, and also adjust the positions of the indication lines, by referring to Item (5) Section ES-5 "Replacing the CDC Sensor."
7. Provisionally turn on the power, and check if the pedal cadence is displayed on the control unit.
8. Assemble the frame cover by referring to the Sections D-1 & D-2 "Removing the Frame Covers."

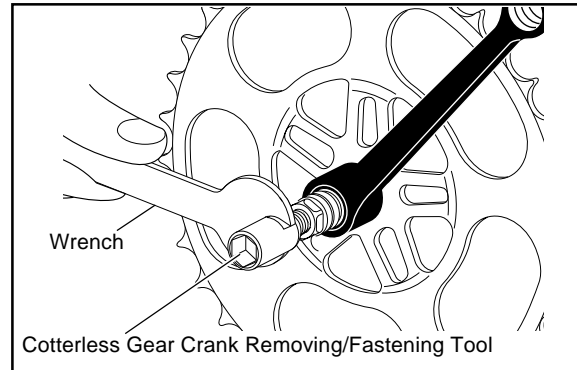

Fig. 1

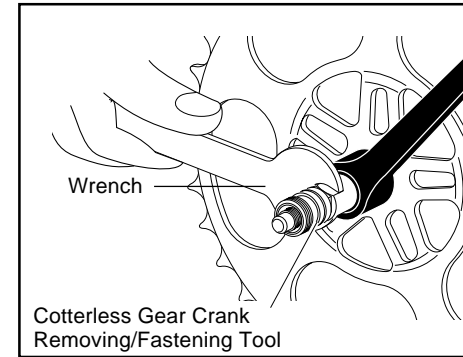

Fig. 2

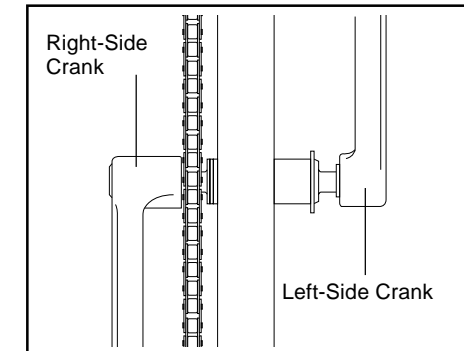

Fig. 3

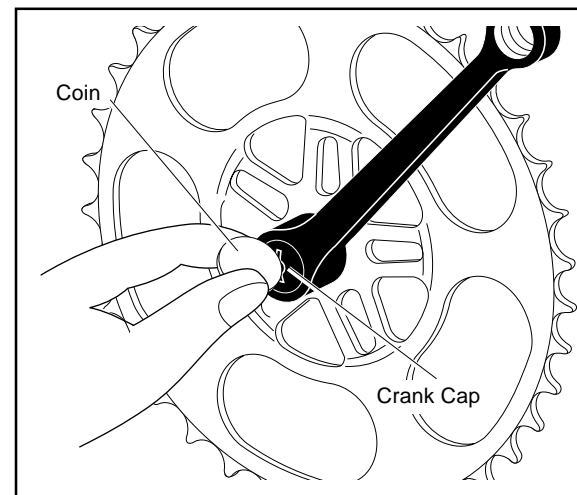

Fig. 4

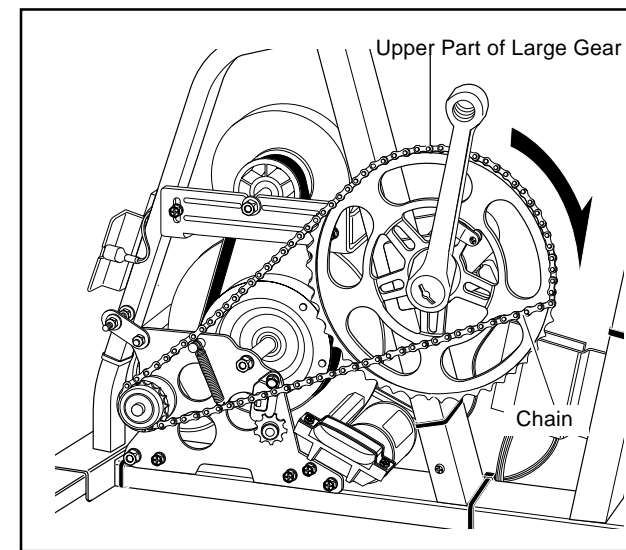

Fig. 5

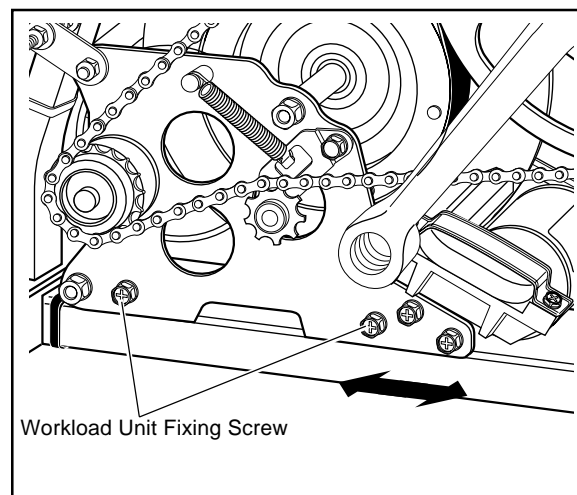

Fig. 6

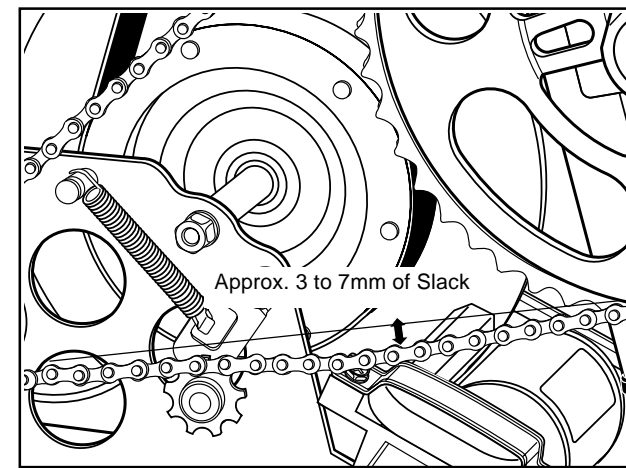

Fig. 7

MS-9 Replacing the BB Set

REMOVAL

1. Remove the frame cover, by referring to the Sections D-1 & D-2 "Removing the Frame Covers."
2. Remove the gear crank/crank from the crank shaft(BB axle), by referring to the Section MS-8 "Replacing the Crank Set."
3. Remove the BB cup locking with a hanger rotating jig. (Fig. 1)
4. Remove the BB adjusting cup, by using a pin face wrench. (Fig. 2)
5. Remove the crank shaft(BB axle).
6. Remove the BB fixing cup, by using the hanger rotating jig. (Fig. 3) The CDC sensor metal base will be removed at the same time.

ASSEMBLING

1. Check if no retainer remains within the hanger, and mount the BB fixing cup. Be sure that the CDC sensor metal base should first be mounted before mounting the BB fixing cup.
2. Assemble the crank shaft(BB axle), retainer, BB fixing cup, BB adjusting cup, BB cup locking and CDC sensor metal base as depicted in Fig. 4.
3. Mount the gear crank/crank, by referring to Mounting Items (1) thru (5), Section-MS-8 "Replacing the Crank Set." Also, adjust the tension of the chain.
4. Adjust the following:
 1. Align the line on the CDC sensor with the center of the line on the magnet. (Fig. 5)
 2. Adjust the clearance between the CDC sensor surface and the magnet surface to be approx. 2mm. (Fig. 6)
- * When the specified clearance has not been established, bend the metal base to have the clearance.
5. Provisionally turn on the power, and check if the pedal cadence is displayed on the control unit.
6. Assemble the frame cover, by referring to the Sections D-1 & D-2 "Removing the Frame Covers."

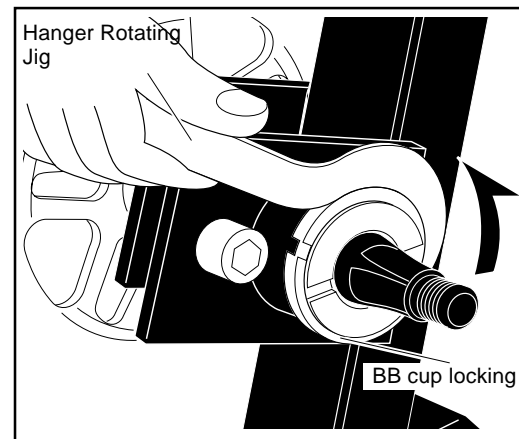
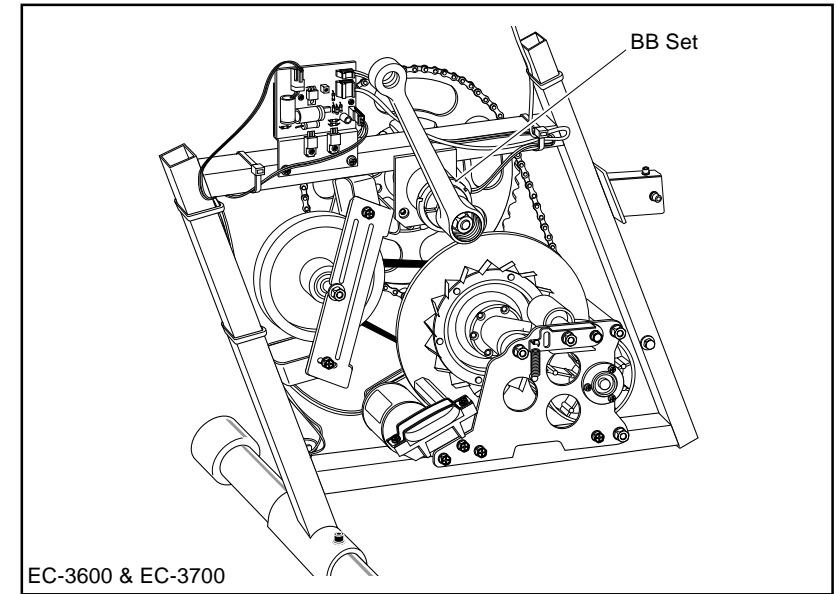
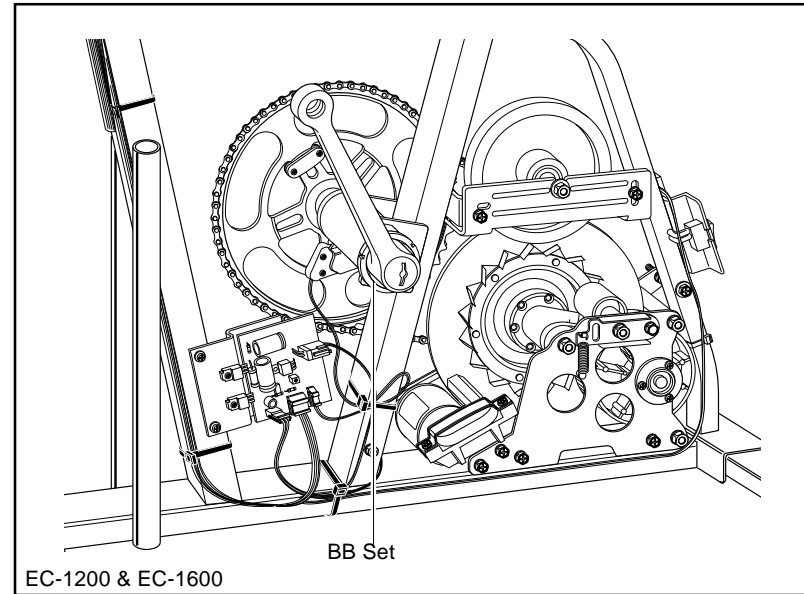

Fig. 1

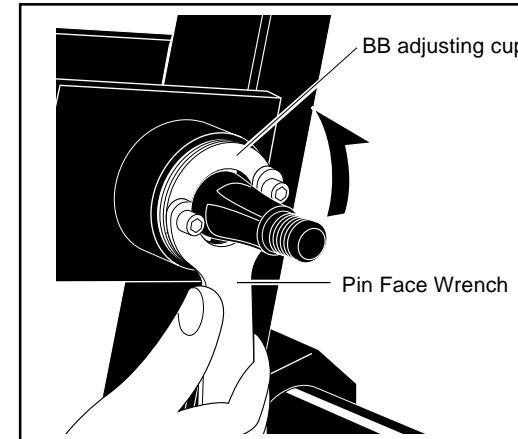

Fig. 2

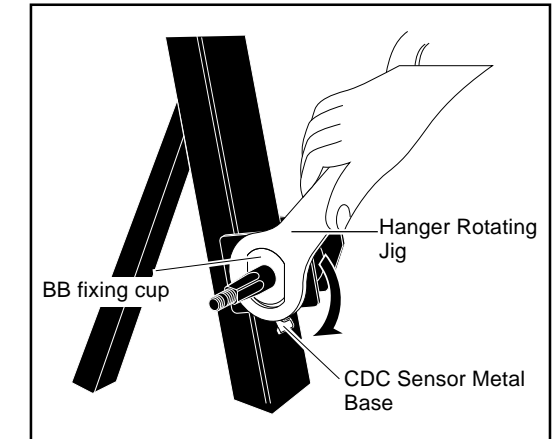

Fig. 3

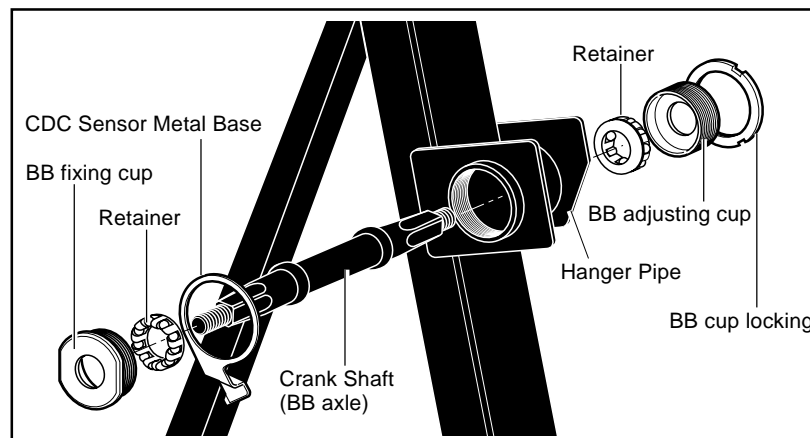

Fig. 4

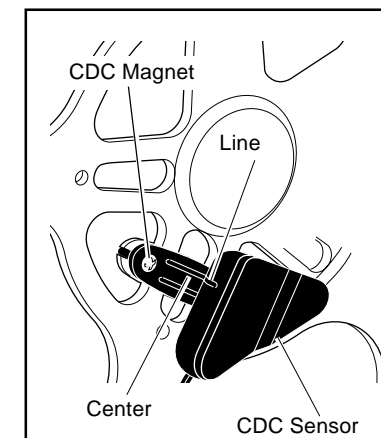

Fig. 5

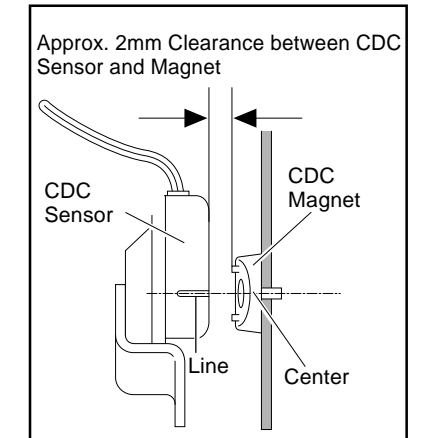

Fig. 6

MS-10 Replacing the Post Spacer

REMOVAL

1. Remove the center cover, by referring to the Section MS-19 "Replacing the Center Cover of Upright Type."
2. Remove the lock nut located at the side of the frame, and then remove the adjust screw. (Fig. 1)
3. Pull out the spacer spring. (Fig. 1)
4. The post spacer can be pulled out upward while the boss at the side of the post is being pressed in with a screwdriver (for both right and left sides). (Fig. 2)

ASSEMBLING

1. Insert a brandnew post spacer.
2. Insert the spacer spring, and slightly fasten the adjust screw. (Fig. 3)
3. Insert the seat post (handlebar post), and adjust the adjust screw so that the post will drop slowly.
4. Fasten the lock nut to lock the adjust screw.
5. Assemble the center cover, by referring to the Section MS-19 "Replacing the Center Cover of Upright Type."

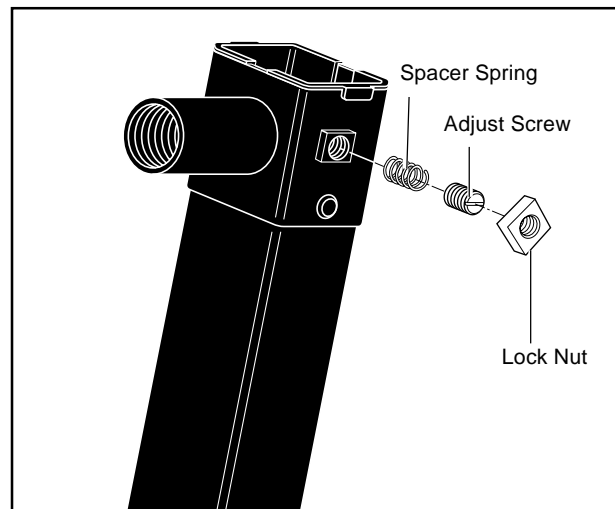

Fig. 1

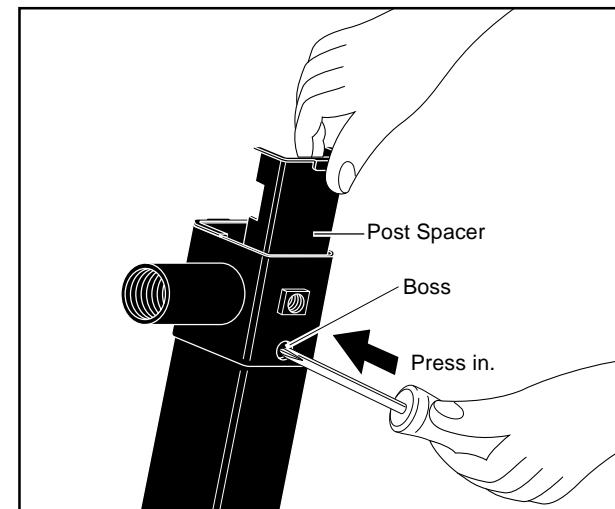

Fig. 2

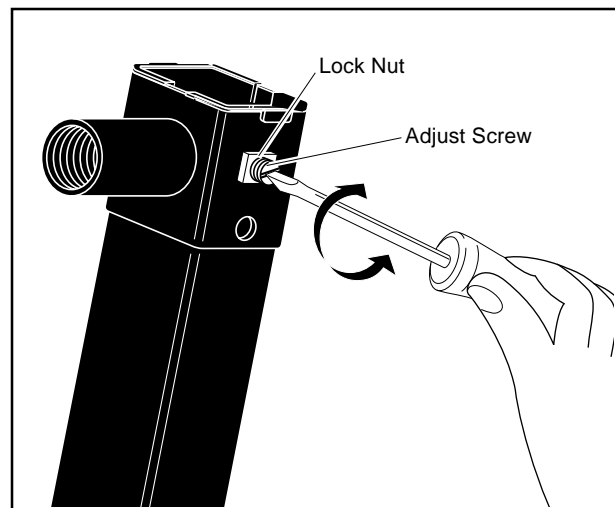

Fig. 3

MS-11 Adjusting the Spacer Spring

1. Remove the center cover, by referring to the Section MS-19 "Replacing the Center Cover of Upright Type."
2. Slightly loosen the lock nut at the side of the frame. (Fig. 1)
3. Fasten the adjust screw so that the seat post (handlebar post) will drop slowly.
4. Fasten the lock nut to fix the adjust screw.
5. Assemble the center cover, by referring to the Section MS-19 "Replacing the Center Cover of Upright Type."

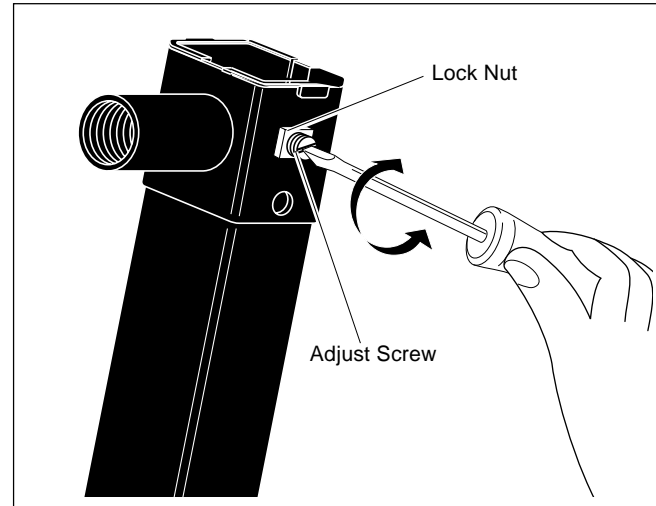

Fig. 1

MS-12 Replacing the Inner Pipe Spacer

REMOVAL

1. Slide the seat pipe to the utmost back end, and set it at a position where the screw head can be seen through the hole on the top surface of the seat pipe.
2. Remove the stopper screw. (Fig. 1)
3. Pull out the seat pipe and the inner pipe spacer A, while depressing the two bosses, located at the right and left sides of the seat pipe, at the same time. (Fig. 2)
4. Remove the spacer B at the end of the inner pipe. (Fig. 3)

ASSEMBLING

1. Set a brandnew inner pipe spacer B into the seat pipe. (Fig. 4)
2. Insert the inner pipe spacer A and B together into the seat pipe.
3. Align the hole on the top surface of the seat pipe with the screw hole, and apply the stopper screw. (Fig. 1)

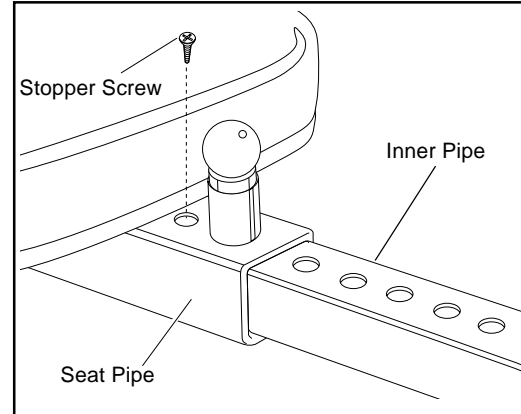

Fig. 1

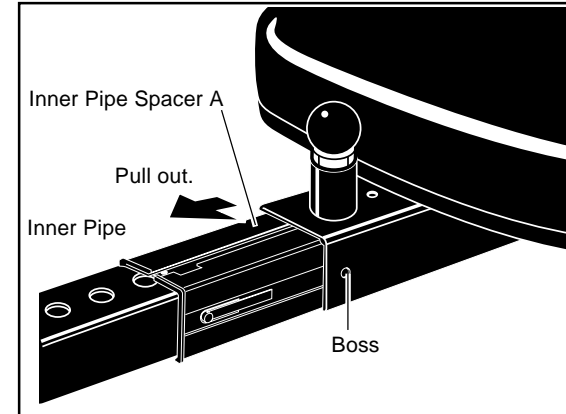

Fig. 2

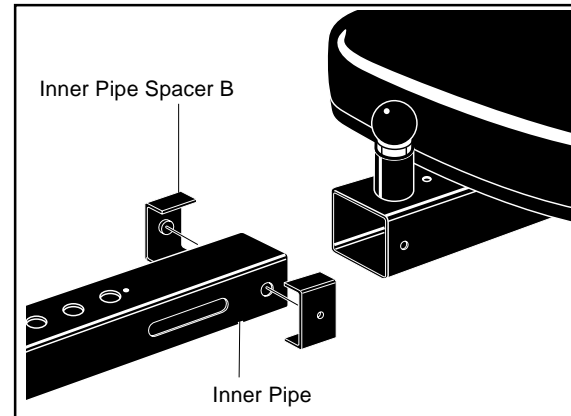

Fig. 3

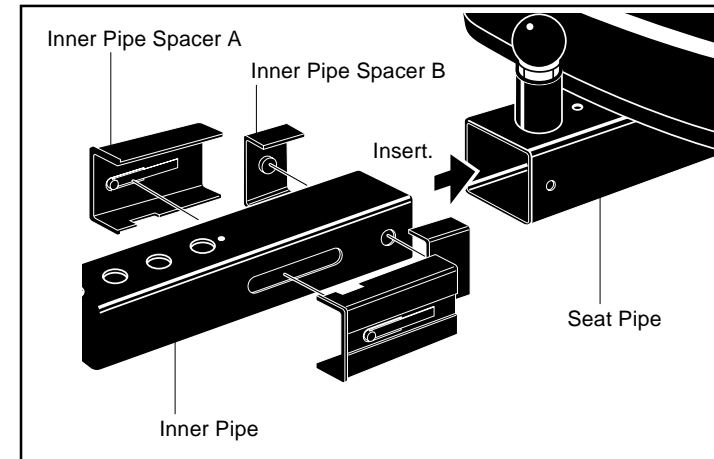

Fig. 4

MS-13 Replacing the Vertical Pipe Spacer

1. Remove the seat hite lock knob, and pull out the rear support pipe.(Fig. 1)
2. Remove the rear support pipe spacer at the rear support pipe insertion area on the top surface of the seat pipe. The rear support pipe spacer is fixed on the pipe with an adhesive tape.
3. Apply and set a brandnew rear support pipe spacer with an adhesive tape.(Fig. 2)
4. Insert the rear support pipe, and fix it with the seat hite lock knob.

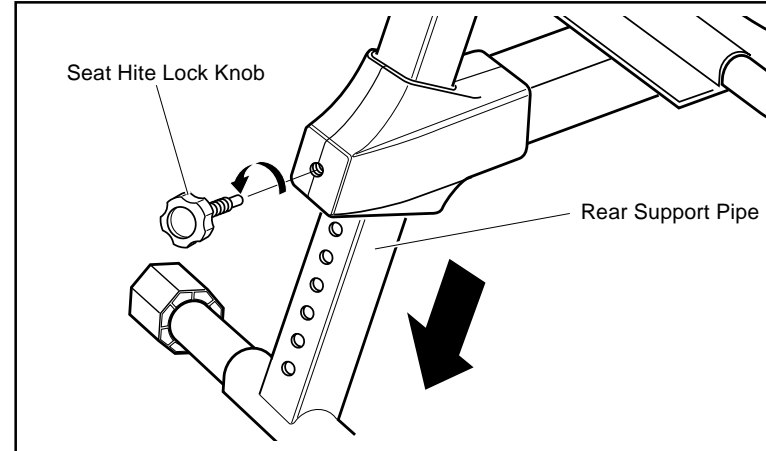

Fig.1

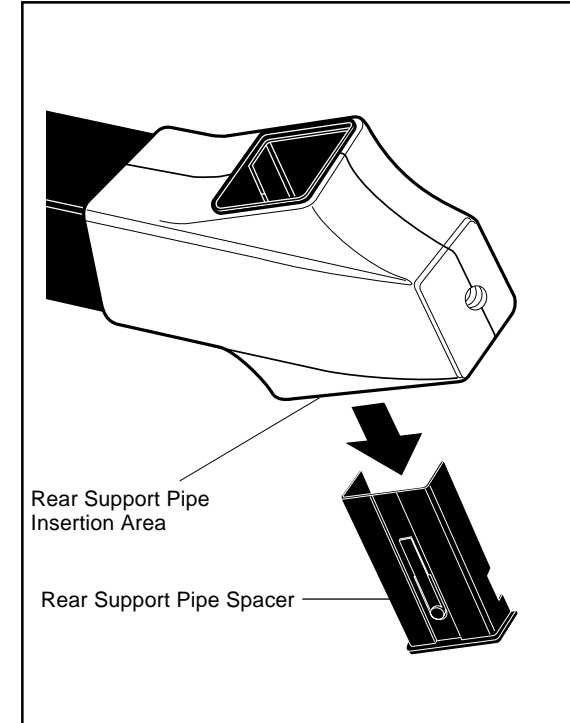

Fig.2

MS-14 Replacing the Leg Cover

■REMOVAL

1. Remove the leg pipe from the main body. Also, remove the levelling knob. (Fig. 1)
2. Apply a screwdriver or the like to the damaged leg cover, and knock the cover off, paying attention not to damage the caster. (Fig. 2)

■ASSEMBLING

1. Set the legcover onto the leg, and hammer it in. The use of a wood block is recommended as a buffer. (Fig. 2)
- * A direct hammering of the leg cover may damage the legcover.
2. Mount the levelling knob and assemble it to the frame.

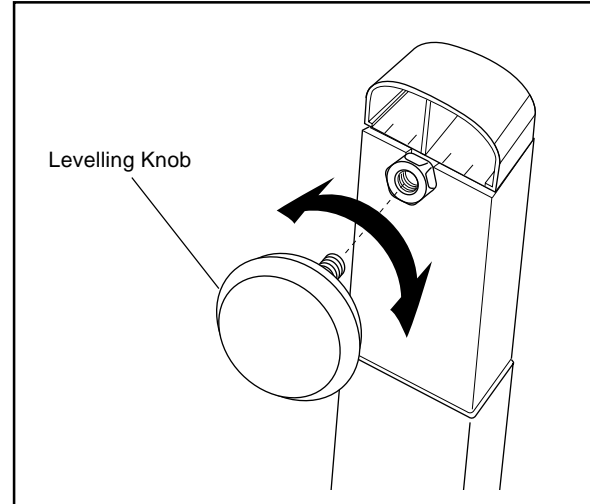

Fig. 1

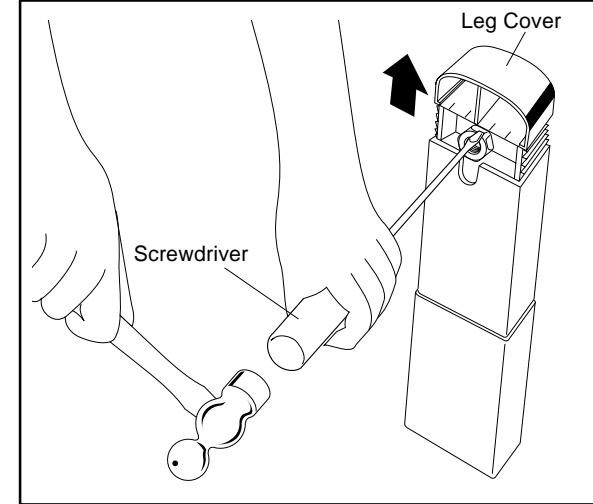

Fig. 2

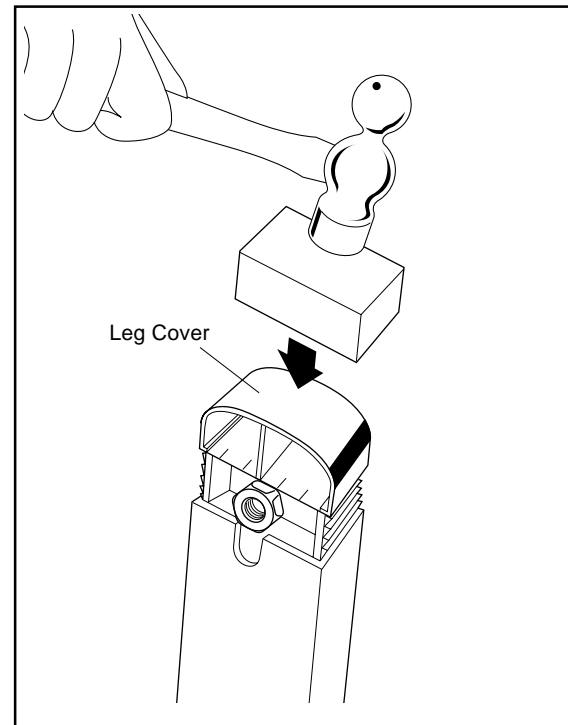

Fig. 3

MS-15 Replacing the Caster and Level Adjuster

1. Loosen the screw and remove the front leg with casters (rear leg with level adjuster) from the main unit (leg).
2. The caster (level adjuster) has been press-fitted into the front leg with casters (rear leg with level adjuster). It can be removed by hammering it through a wooden block. (Fig. 1)
3. Press fit a brandnew caster (level adjuster) with a hammer and a wood block. (Fig. 2)
4. Mount the front leg with casters (rear leg with level adjuster) to the main unit (leg).

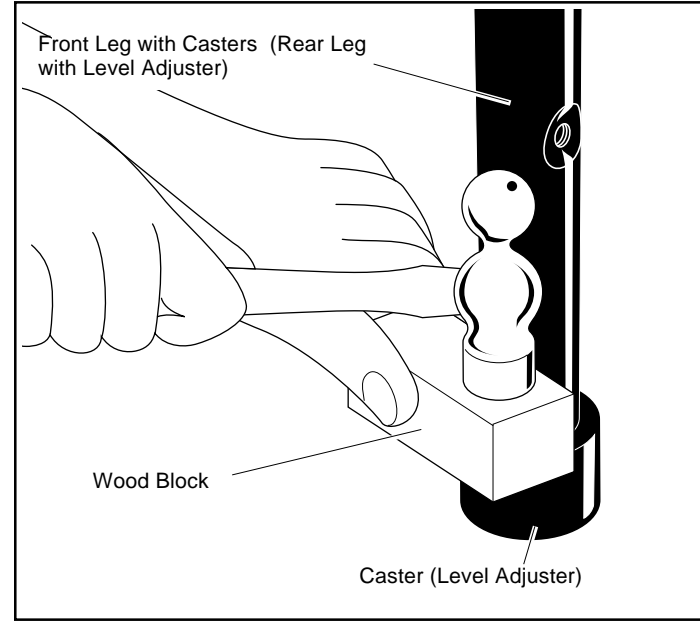

Fig. 1

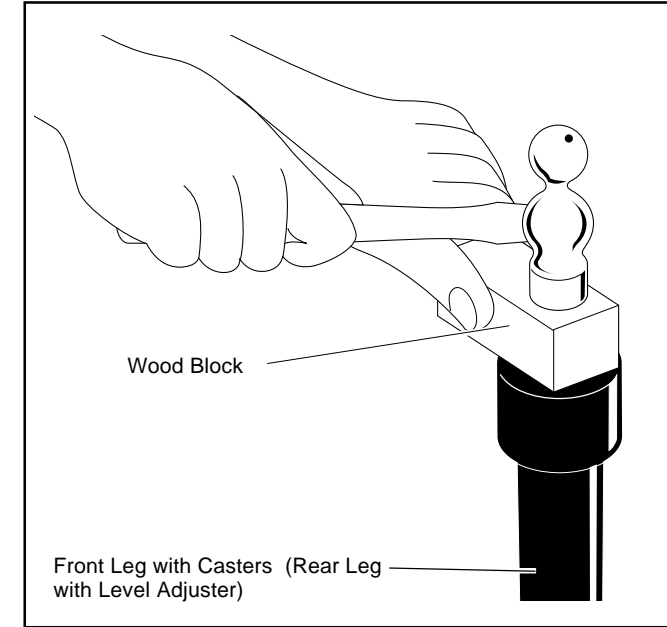

Fig. 2

MS-16 Replacing the Seat Post Knob

1. Pull out the seat post.
2. Remove the seat post knob by rotating and loosening the guide screw in the counter-clockwise direction.
3. Mount a brandnew seat post knob by securely tightening the guide screw.
4. Insert the seat post.

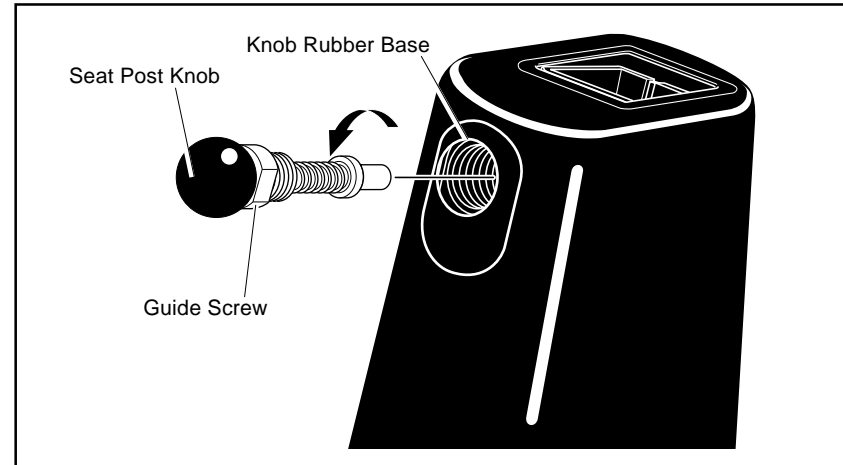

Fig. 1

MS-17 Replacing the Lock Pin

1. Remove the lock pin by rotating and loosening the guide screw in the counter-clockwise direction.
2. Mount a brandnew lock pin by securely tightening the guide screw.

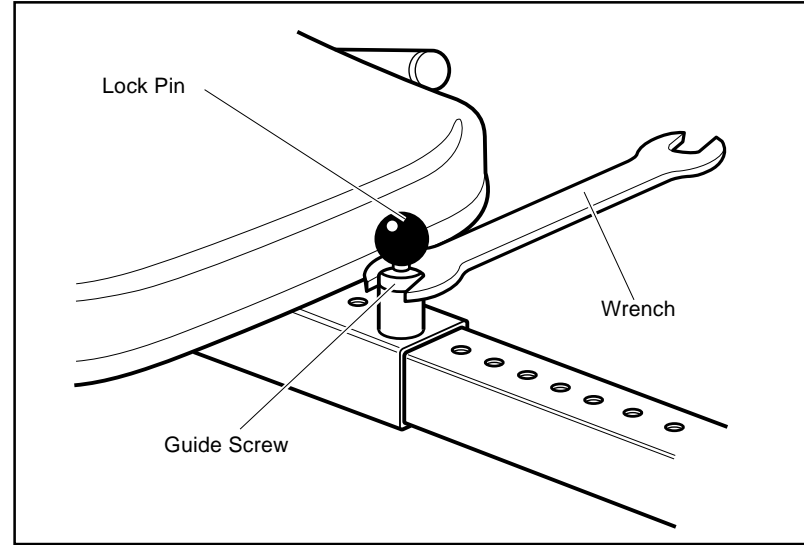

Fig. 1

MS-18 Replacing the Crank Cover

REMOVAL

1. Remove both right and left pedals. (Fig. 1)
2. Loosen and remove the fixing screw on the surface of the crank cover. The narrow-width area of the crank cover should position in between the frame cover and the crank. (Figs 2 & 3)

ASSEMBLING

1. Pass the crank through the hole on the crank cover, and fix the crank cover onto the frame cover with screws. (Figs. 2 & 3)
2. Set the right and left pedals.

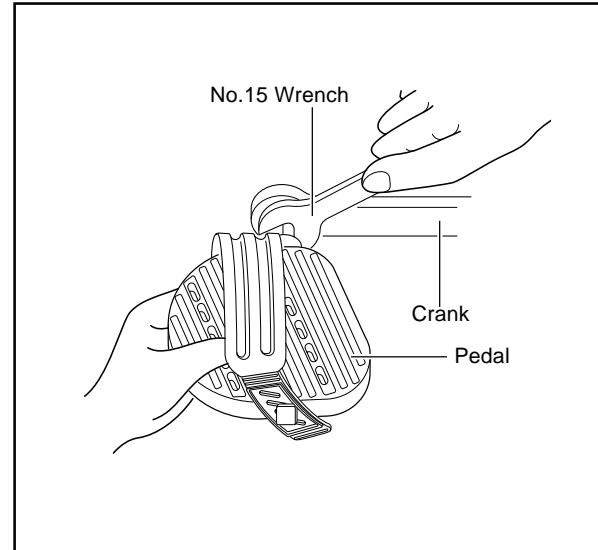

Fig. 1

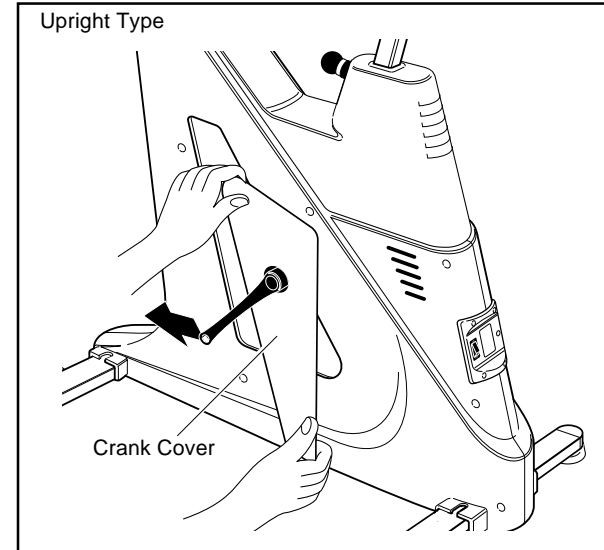

Fig. 2

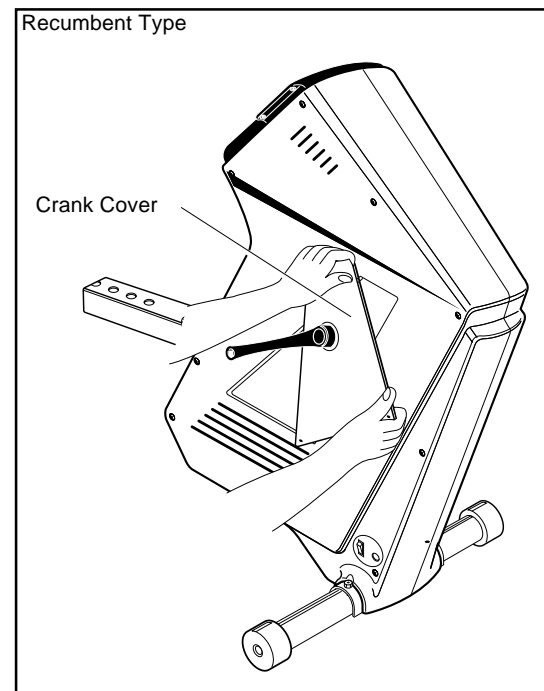

Fig. 3

MS-19 Replacing the Center Cover of Upright Type

1. Loosen the four screws on the bottom of the control unit, remove the control unit, and then detach the cable connector. (Fig. 1)
2. For EC-1600, slide the inner pipe of the handlebar post cover upward, and detach the 5P cable connector (Fig. 2). For EC-1200, remove the cable holder from the handlebar post.
3. Loosen the handlebar post knob, and pull out the handlebar post from the main unit. (Fig. 3)
4. Pull the seat post knob upward, and pull out the seat post from the main unit. (Fig. 4)
5. Loosen and remove the guide screw of the seat post knob. (Fig. 5)
6. Remove the rubber base of the seat post knob. (Fig. 6)
7. Slightly loosen the center cover fixing screws (6 pieces), and remove the center cover by pulling it upward. (Fig. 7)
8. The assembling of the center cover can be made in the procedures opposite to the above.

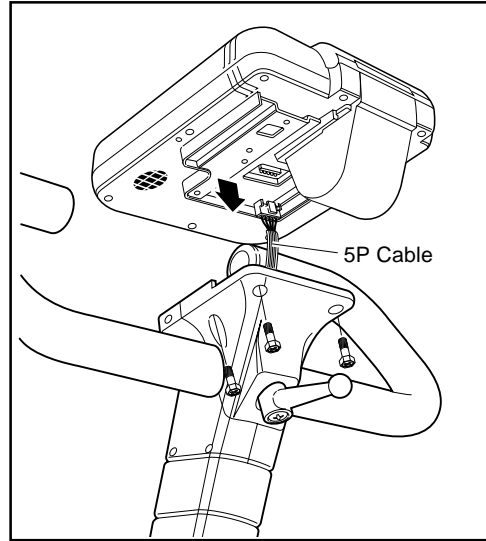

Fig. 1

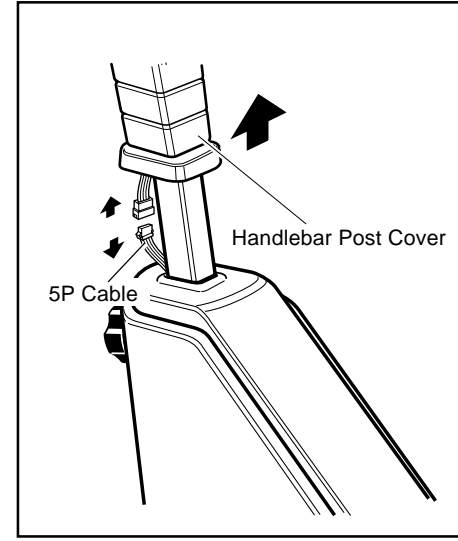

Fig. 2

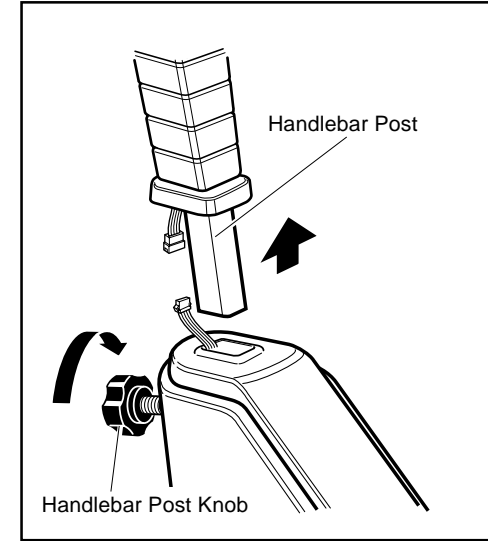

Fig. 3

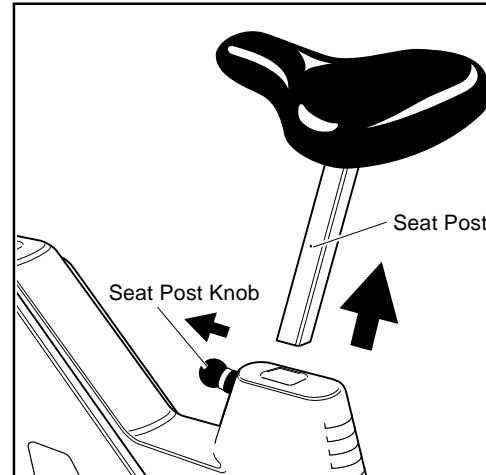

Fig. 4

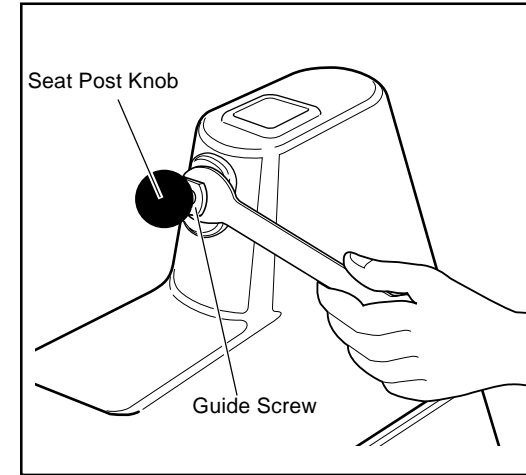

Fig. 5

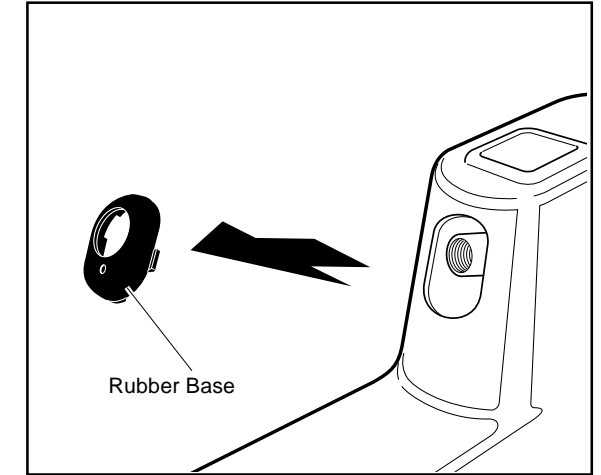

Fig. 6

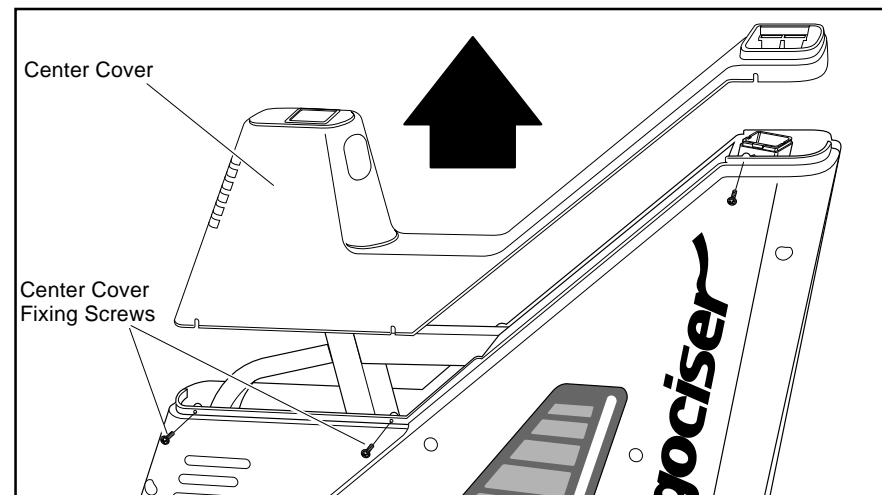

Fig. 7

MS-20 Replacing the Center Cover of Recumbent Type

* Remove the pulse rate sensor, if it is connected, before proceeding to the following procedures.

1. Remove the control unit fixing screws (4 pieces) from the main unit. (Fig. 1)
2. Detach the cable connector from the control unit. (Fig. 2)
3. Loosen and remove the inner pipe from the joint metal base. (Fig. 3)
4. Remove the frame cover fixing screws, and the frame cover will be separated into right and left parts. (Fig. 4)
5. Remove the latch of the center cover from the frame cover, and pull the center cover toward the joint metal base to remove it. (Fig. 5)
6. Assembling of the center cover can be performed in reversed procedure of the above.

* Pull the 5P cable connector out of the center cover through the hole on the cover, and tentatively hold it with an adhesive tape so that it may not be retracted.

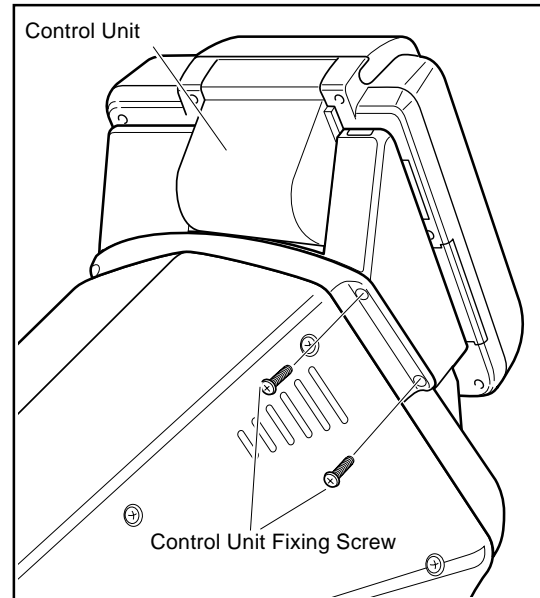

Fig. 1

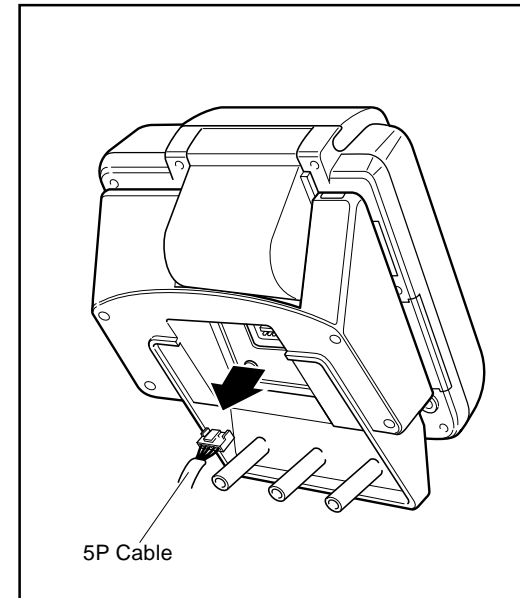

Fig. 2

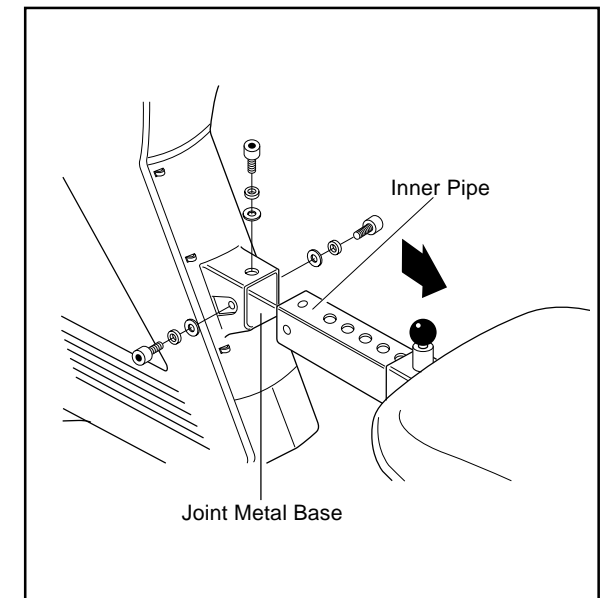

Fig. 3

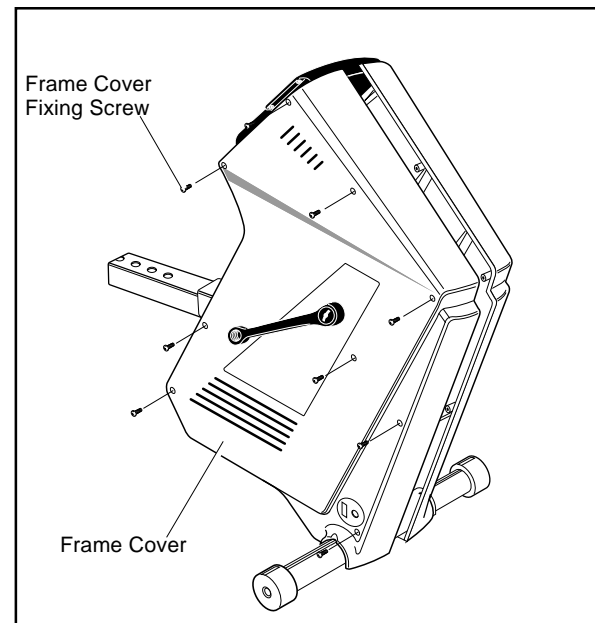

Fig. 4

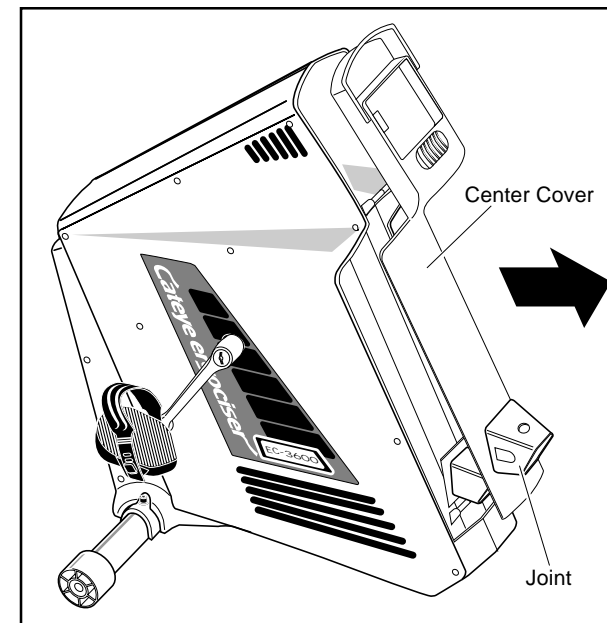

Fig. 5

MS-21 Replacing the Handlebar Grip

1. In case the handlebar grip is damaged, cut the grip with a thin cutting knife and peel it off the handlebar.(Fig. 1)
 2. Fit a brandnew handlebar grip onto the handlebar, utilizing compressed air from a compressor, etc. Press the grip into the handlebar while applying compressed air at one end.(Fig. 2)
- * When a compressor is not available, apply a soap water on the handlebar, and insert the grip while twisting and pressing the grip.
 - * When the above replacing work is difficult to achieve, remove the handlebar before the work.

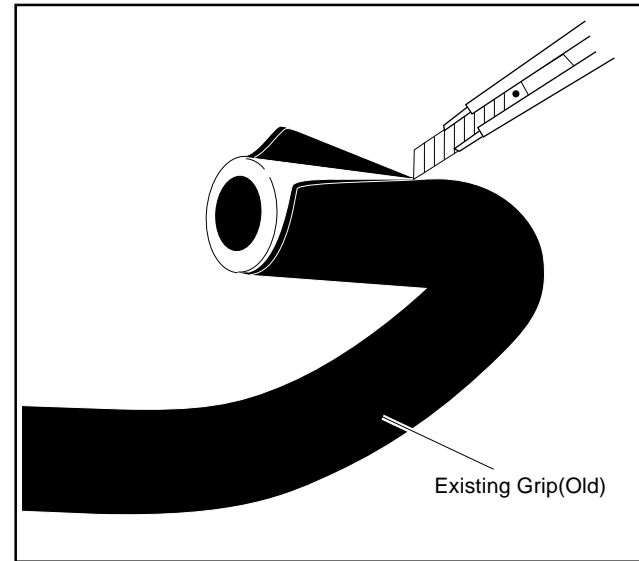

Fig.1

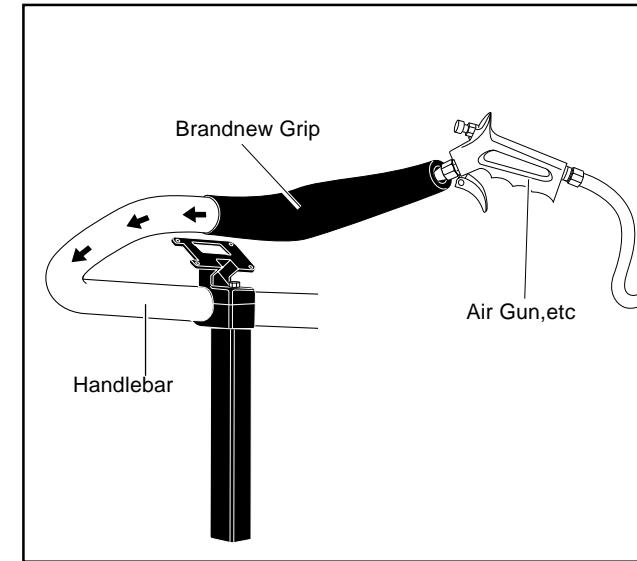

Fig.2

MS-22 Replacing the Printer Cover

1. See the Items (1 & 2), Section ES-6 "Replacing the Panel Keyboard."
2. Detach the existing printer cover, and mount the brandnew printer cover.
3. See the Item (8 & 9), Section ES-6 "Replacing the Panel Keyboard."

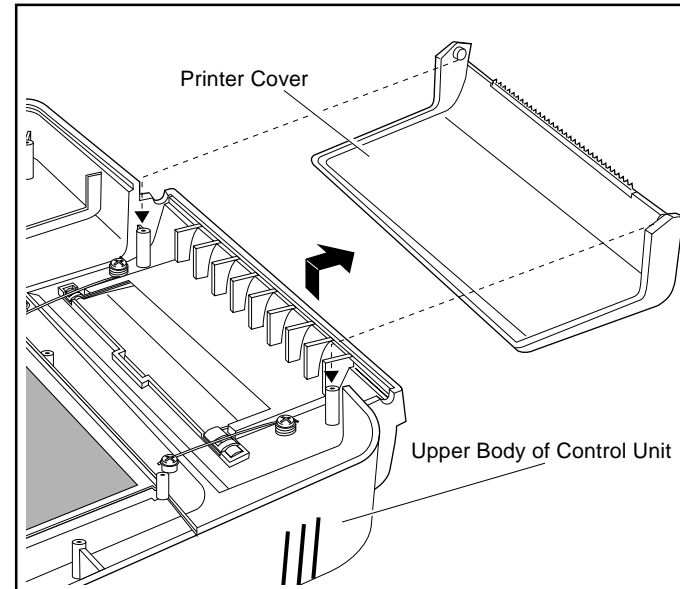

Fig.1

MS-23 Replacing the Paper Cutter

1. See the Items (1 & 2), Section ES-6 "Replacing the Panel Keyboard."
2. Loosen and remove four screws. Also, remove the spring. (Fig. 1)
3. Remove the existing printer cutter, and mount a brandnew paper cutter.
4. Set the spring so that it will fit into the groove of the paper cutter, and fix it with four screws.
5. See the Item (8 & 9), Section ES-6 "Replacing the Panel Keyboard."

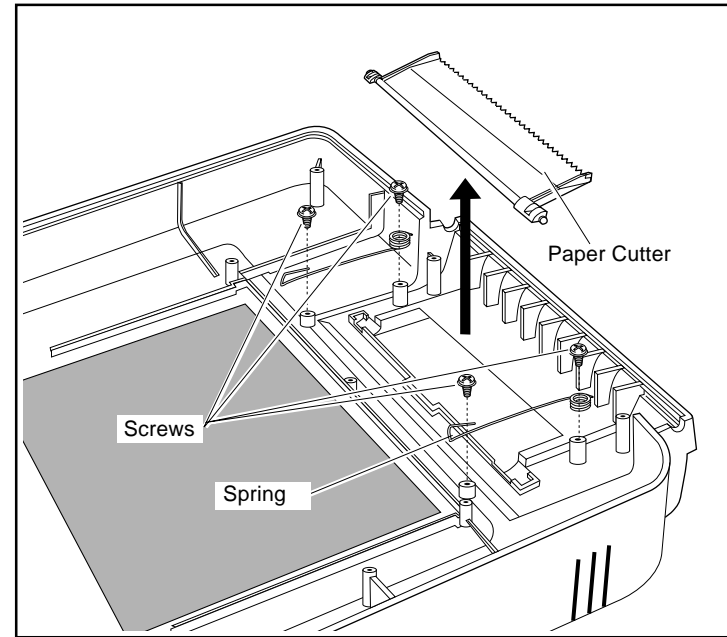
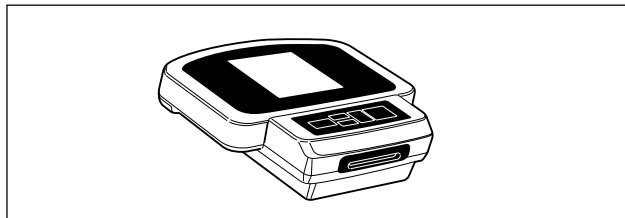
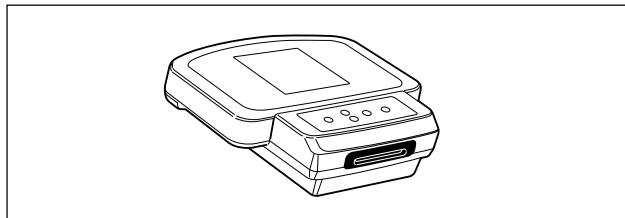

Fig. 1



PNR.780-6101 EC-1200 Control Unit(E) Ivory
 PNR.780-6102 EC-1200 Control Unit(G) Ivory
 PNR.780-6106 EC-1200 Control Unit(E) Black
 PNR.780-6107 EC-1200 Control Unit(G) Black
 unit: pieces



PNR.780-6108 EC-1200 Control Unit Multi Ivory
 PNR.780-6109 EC-1200 Control Unit Multi Black
 unit: pieces

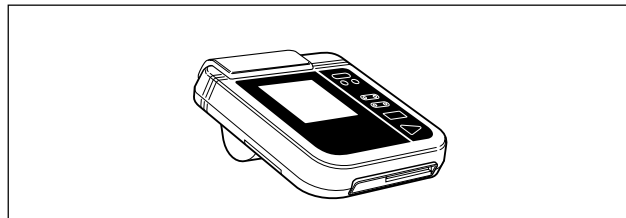

PNR.780-6501 EC-1600 Control Unit(E) Ivory
 PNR.780-6502 EC-1600 Control Unit(G) Ivory
 PNR.780-6506 EC-1600 Control Unit(E) Black
 PNR.780-6507 EC-1600 Control Unit(G) Black
 unit: pieces

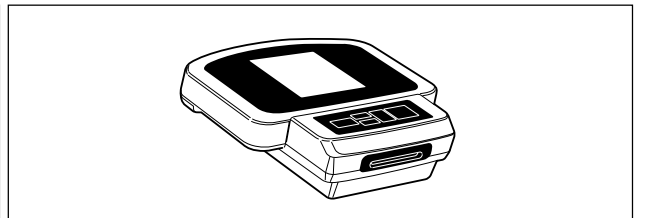

PNR.781-5601 EC-3600 Control Unit(E) Ivory
 PNR.781-5602 EC-3600 Control Unit(G) Ivory
 PNR.781-5606 EC-3600 Control Unit(E) Black
 PNR.781-5607 EC-3600 Control Unit(G) Black
 unit: pieces

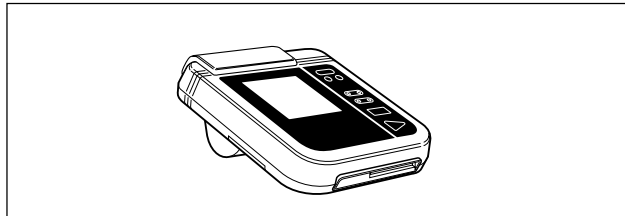

PNR.781-5901 EC-3700 Control Unit(E) Ivory
 PNR.781-5902 EC-3700 Control Unit(G) Ivory
 PNR.781-5916 EC-3700 Control Unit(E) Black
 PNR.781-5917 EC-3700 Control Unit(G) Black
 unit: pieces

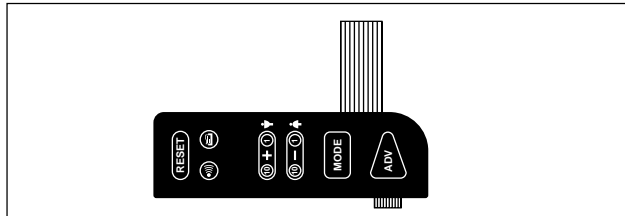

PNR.780-5160 EC-1600/3700 Panel Keyboard
 unit: sets

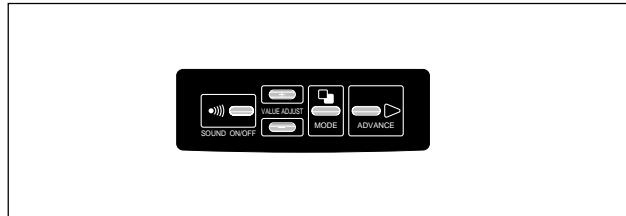

PNR.780-6120 EC-1200 Button Panel(E)
 PNR.780-6121 EC-1200 Button Panel(G)
 unit: sets

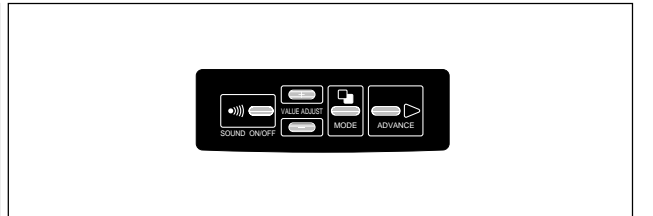

PNR.781-5611 EC-3600 Button Panel(E)
 PNR.781-5610 EC-3600 Button Panel(G)
 unit: sets

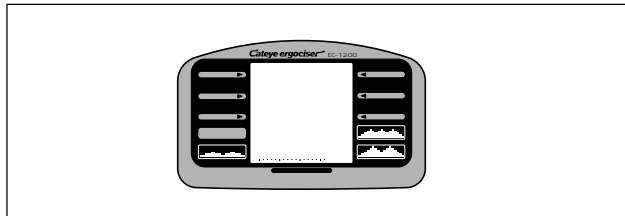

PNR.000-0000 EC-1200 Decal(E)
 PNR.000-0000 EC-1200 Decal(G)
 PNR.000-0000 EC-1200 Decal(F)
 unit: sets

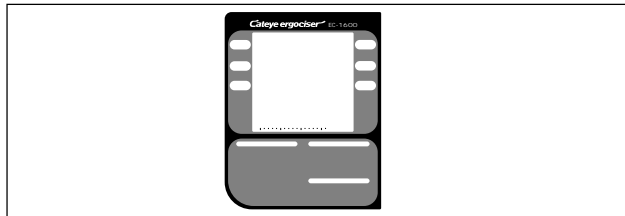

PNR.000-0000 EC-1600 Decal(E)
 PNR.000-0000 EC-1600 Decal(G)
 PNR.000-0000 EC-1600 Decal(F)
 unit: sets

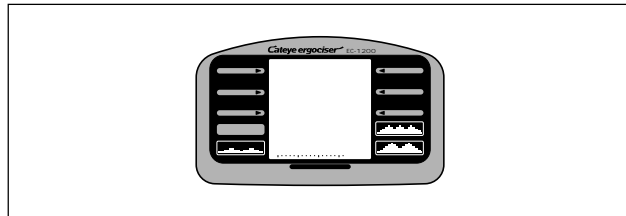

PNR.000-0000 EC-3600 Decal(E)
 PNR.000-0000 EC-3600 Decal(G)
 PNR.000-0000 EC-3600 Decal(F)
 unit: sets

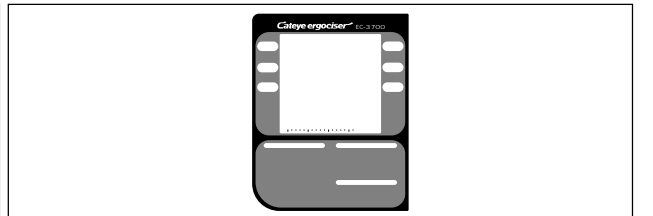

PNR.000-0000 EC-3700 Decal(E)
 PNR.000-0000 EC-3700 Decal(G)
 PNR.000-0000 EC-3700 Decal(F)
 unit: sets

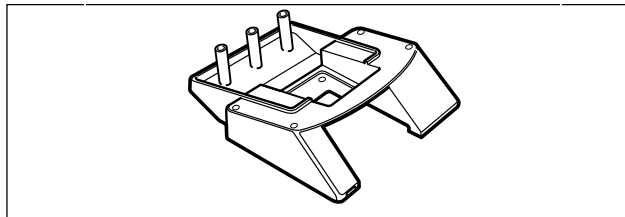

PNR.000-0000 EC-3700 Unit Base
 unit: pieces

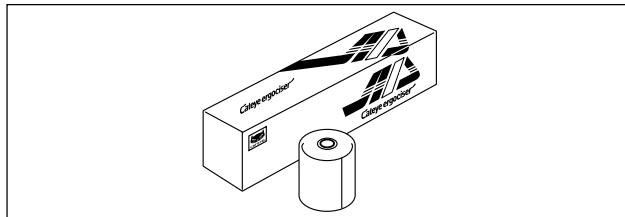

PNR.722-6502 Thermal Paper(E)
 unit: sets

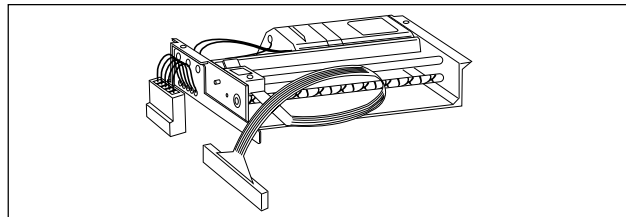

PNR.736-6000 EC-1600/3700 Printer Unit
 unit: sets

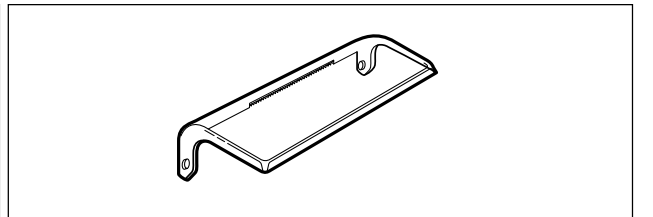

PNR.780-5111 EC-1600/3700 Printer Cover
 unit: pieces

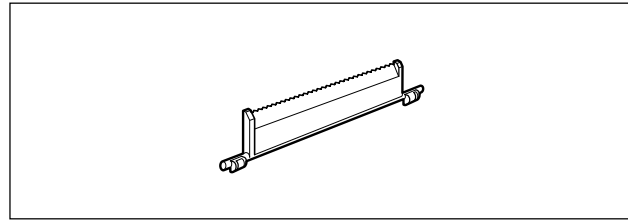

PNR.780-1031 EC-1600/3700 Paper Cutter
unit: pieces

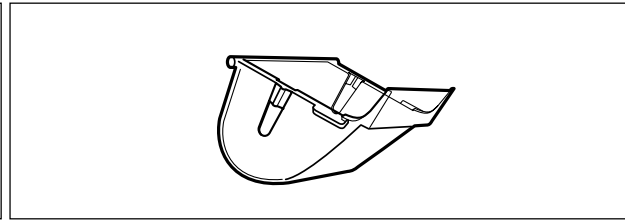

PNR.780-1020 Paper Case
unit: pieces

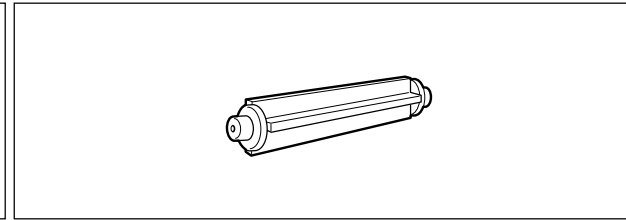

PNR.780-1030 Paper Roller
unit: pieces

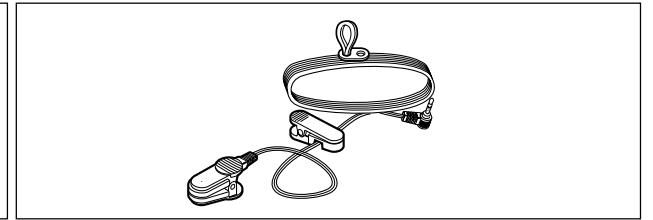

PNR.780-1100 EC-1200/1600 Pluse Sensor Set (1M)
PNR.780-1102 EC-1200/1600 Pluse Sensor Set (1.5M)
PNR.780-1101 EC-3600/3700 Pluse Sensor Set (2M)
unit: sets

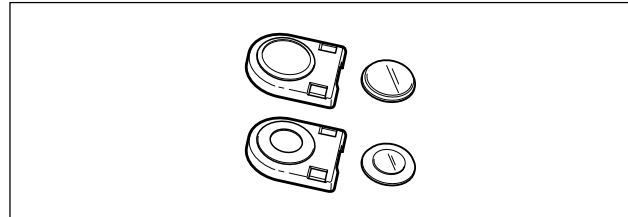

PNR.780-1110 Pluse Sensor Cover Set
unit: sets

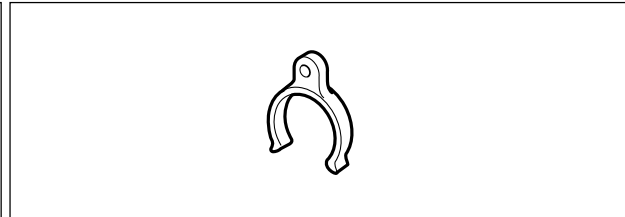

PNR.780-1200 Sensor Clip
unit: pieces

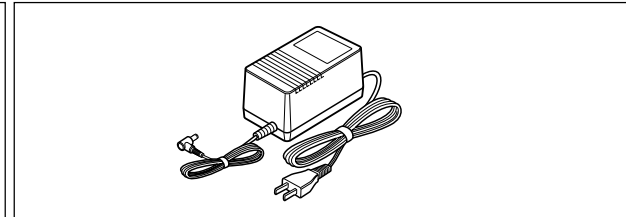

PNR.737-5500 AC Adepter J (100V)
PNR.737-5511 AC Adepter UL (120V)
PNR.737-5520 AC Adepter EC (220V)
PNR.737-5523 AC Adepter UK (240V)
unit: sets



PNR.781-9100 Saddle (SMP1209)
unitsets



PNR.703-3101 EC-3600/3700 Recumbent Seat
unit: sets

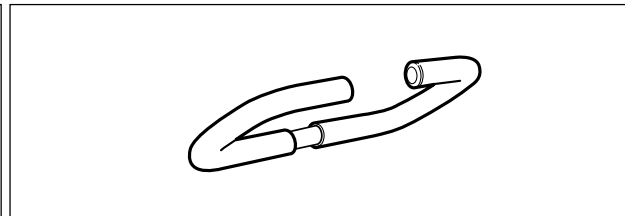

PNR.724-3410 EC-1200 Handlebar
PNR.780-6450 EC-1600 Handlebar
unit: pieces

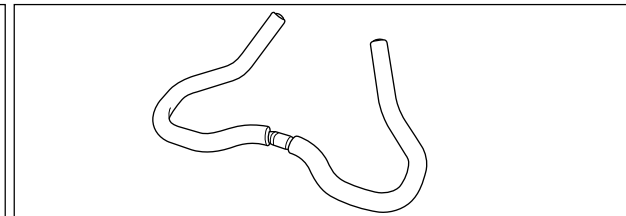

PNR.781-9000 Sporty Handlebar Set (HB-100)
unit: pieces

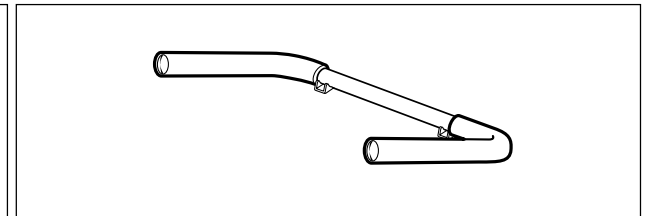

PNR.781-5130 EC-3600/3700 Handlebar
unit: pieces

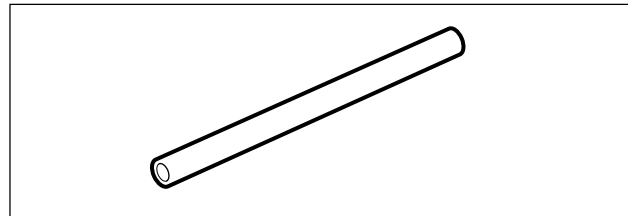

PNR.725-0000 EC-1200 Handlebar Grip
PNR.780-6470 EC-1600 Handlebar Grip
PNR.781-5060 EC-3600/3700 Handlebar Grip
unit: pieces

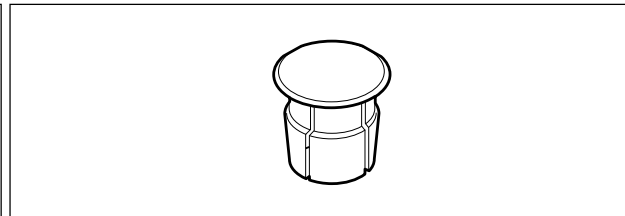

PNR.781-3200 Handlebar Cap
unit: pieces

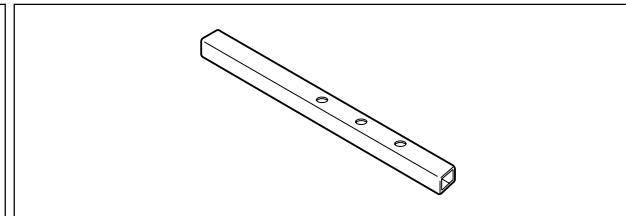

PNR.781-0210 EC-1200/1600 Handlebar Post
unit: pieces

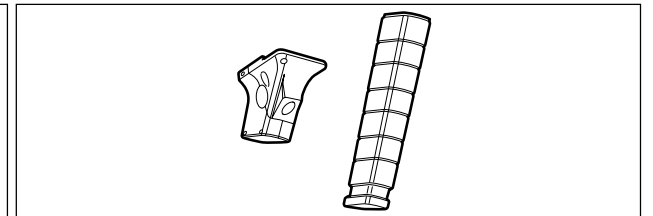

PNR.780-6430 EC-1600 Handlebar Post Cover Set
unit: sets

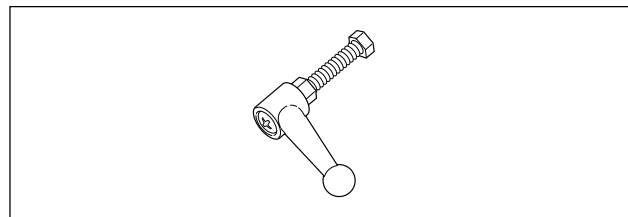

PNR.758-5000 EC-1200/1600 Handlebar Lever Set
unit: sets

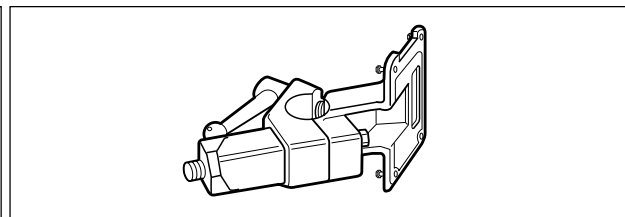

PNR.780-6170 EC-1200/1600 Handlebar Stem
unit: sets

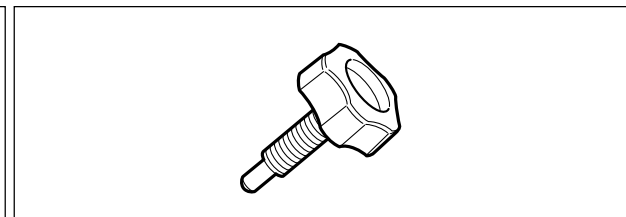

PNR.785-1416 Adjusting Knob/Seat Hite Lock Knob
unit: pieces

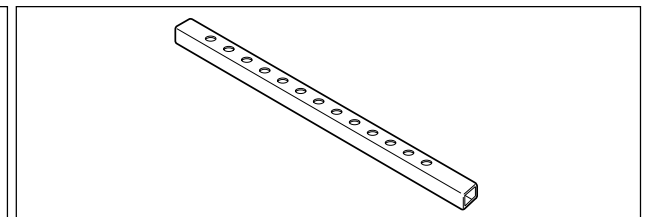

PNR.780-6190 EC-1200/1600 Seat Post
unit: pieces

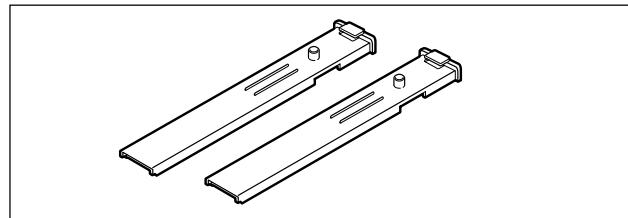

PNR.780-6050 EC-1200/1600 Post Spacer Set
unit: sets

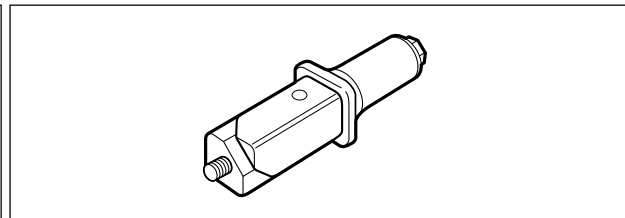

PNR.780-9610 EC-1200/1600 Seat Pillar
unit: pieces

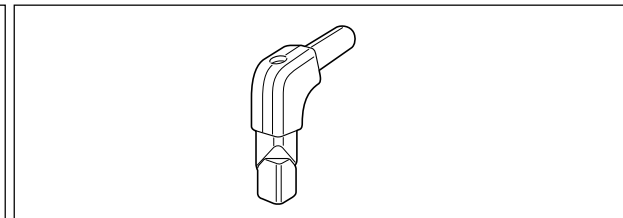

PNR.780-6260 EC-1200 New Seat Pillar
unit: pieces

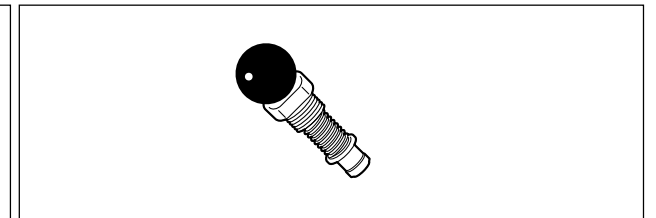

PNR.785-1417 EC-1200/1600 Seat Post Knob
unit: pieces

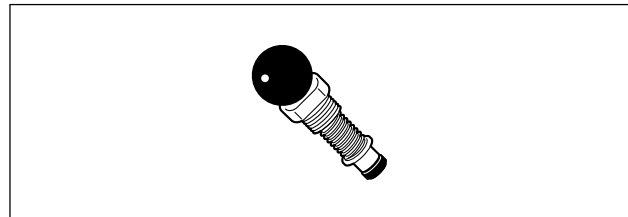

PNR.781-5120 EC-3600/3700 Lock Pin
unit: pieces

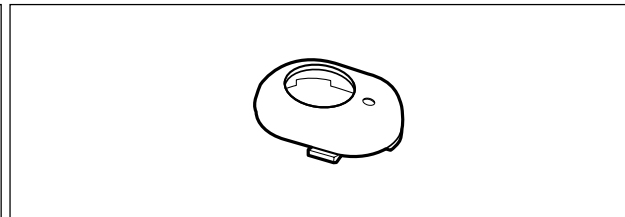

PNR.780-6040 EC-1200/1600 Rubber Base for Knob
unit: pieces

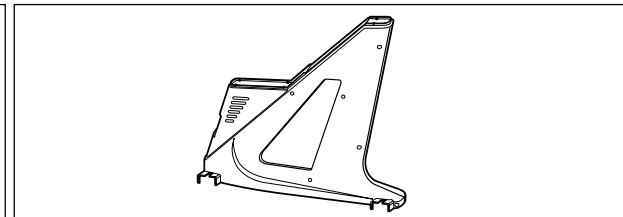

PNR.780-6000 EC-1200/1600 Frame Cover(L/R) Ivory
PNR.780-6001 EC-1200/1600 Frame Cover(L/R) Black
unit: sets

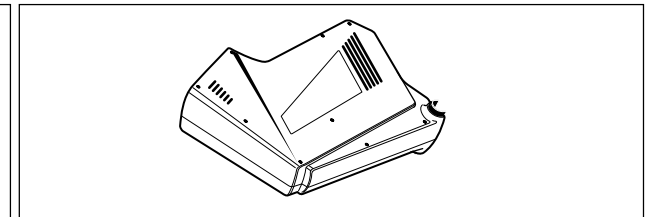

PNR.781-5000 EC-3600/3700 Frame Cover(L/R) Ivory
PNR.781-5001 EC-3600/3700 Frame Cover(L/R) Black
unit: sets

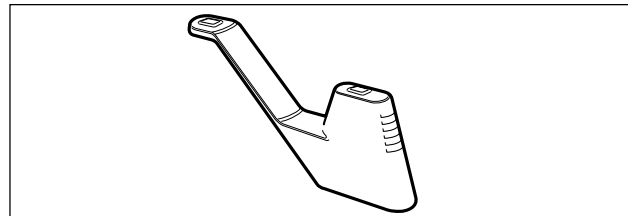

PNR.780-6010 EC-1200/1600 Center Cover
unit: pieces

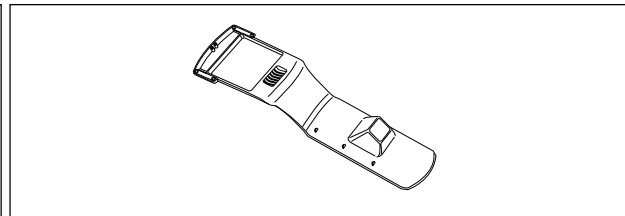

PNR.781-5500 EC-3600/3700 Center Cover
unit: pieces

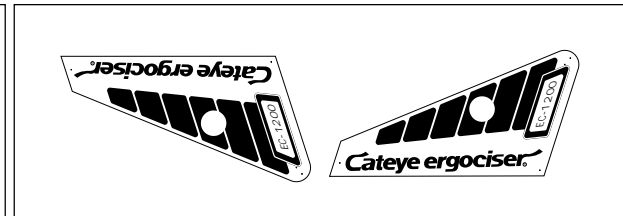

PNR.780-6020 EC-1200 Crank Cover(L,R)Set
unit: sets

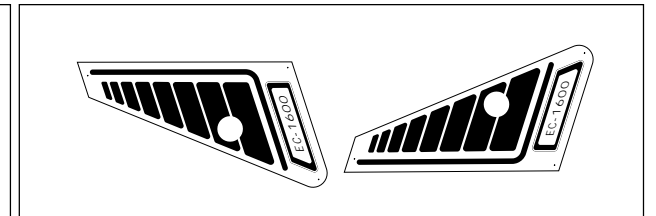

PNR.780-6420 EC-1600 Crank Cover(L,R)Set
unit: sets

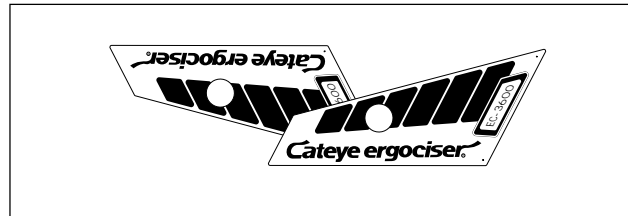

PNR.781-5520 EC-3600 Crank Cover(L,R)Set
unit: sets

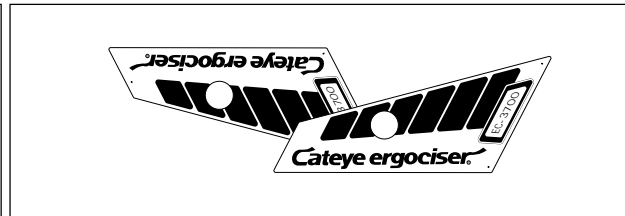

PNR.781-5810 EC-3700 Crank Cover(L,R)Set
unit: sets

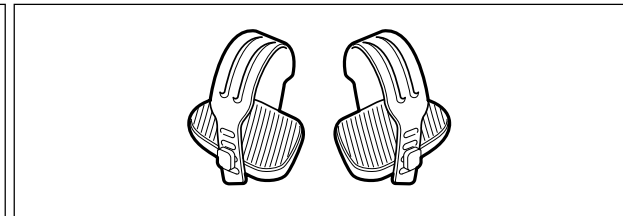

PNR.781-5100 Pedal(L,R)
unit: sets

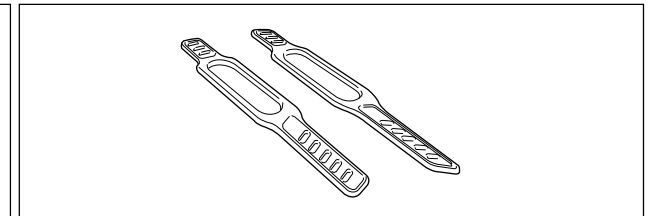

PNR.781-9300 Pedal Belt E-16 (L,R)
unit: sets

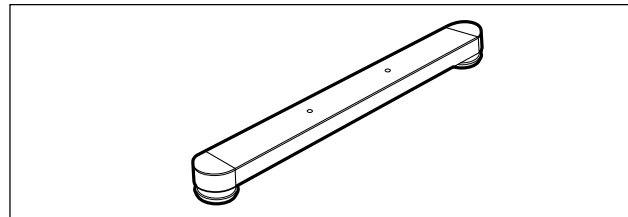

PNR.780-6160 EC-1200/1600 Rear Leg with Level Adjuster
unit: pieces

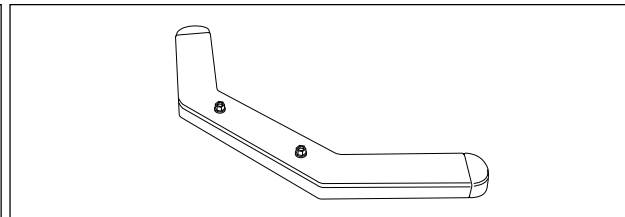

PNR.780-6160 EC-1200/1600 Mod. Rear Leg
unit: pieces

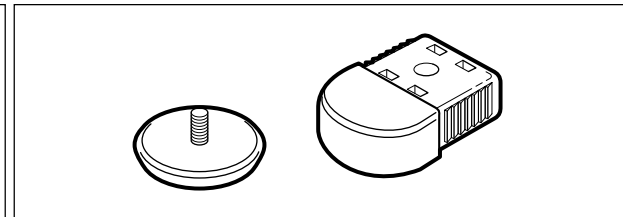

PNR.780-0140 EC-1200/1600 Leveler Set
unit: sets

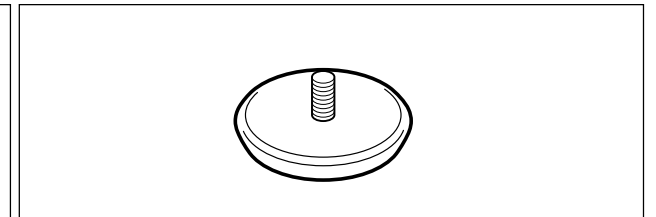

PNR.724-3950 EC-1200/1600 Levelling Knob
unit: pieces

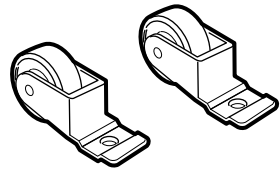

PNR.780-6180 EC-1200/1600 Caster Pipe Set
unit: sets

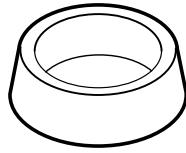

PNR.780-6550 EC-1600 Vibration-proof Rubber
unit: pieces

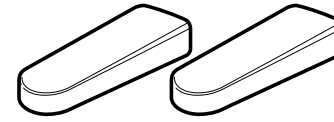

PNR.780-6445 EC-1200/EC-1600 Front Leg with Cover Set
unit: sets

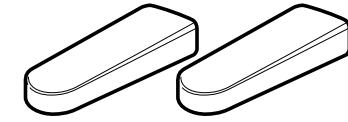

PNR.780-6446 EC-1200/EC-1600 Rear Leg with Cover Set
unit: sets

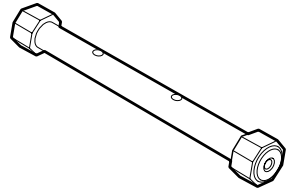

PNR.786-2409 EC-3600/3700 Rear Leg with Level Adjuster
unit: pieces

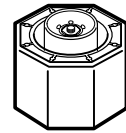

PNR.781-0140 EC-3600/3700 Leveler Set
unit: pieces

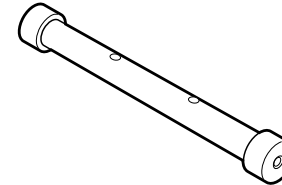

PNR.787-2409 EC-3600/3700 Caster Pipe Set
unit: pieces



PNR.781-0150 EC-3600/3700 Caster Set
unit: pieces

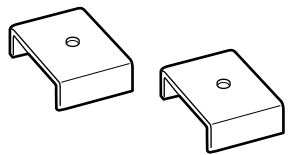

PNR.781-5030 EC-3600/3700 Pipe Spacer Set
unit: sets

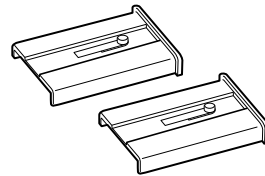

PNR.781-5040 EC3600/3700 Rear Support Pipe Spacer Set
unit: sets

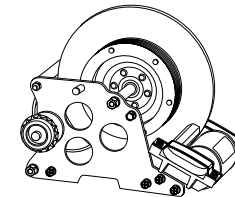

PNR.780-2000 EC-1200 Workload Unit
PNR.780-6310 EC-1600/1200G Workload Unit (w/Flywheel)
PNR.781-5580 EC-3600/3700 Workload Unit (w/Flywheel)
unit: pieces

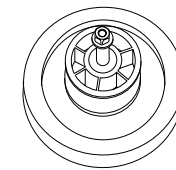

PNR.780-2240 Freewheel Set
unit: sets

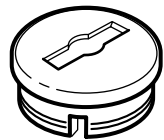

PNR.724-4802 Crank Cap
unit: sets

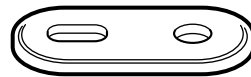

PNR.718-0450 EC-1200/1600 Workload Unit Reinforcing Metal Base
unit: pieces

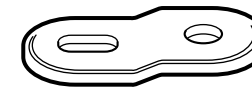

PNR.781-5580 EC-3600/3700 Workload Unit Reinforcing Metal Base
unit: pieces

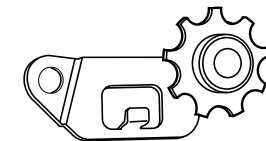

PNR.780-2200 Derailleur Set
unit: set

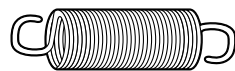

PNR.720-1110 Derailleur Spring
unit: set

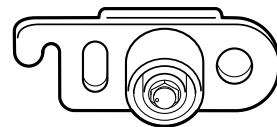

PNR.780-2220 Idler Set
unit: sets



PNR.720-1110 Idler Spring
unit: pieces

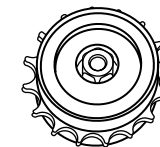

PNR.780-2240 Freewheel Set
unit: sets

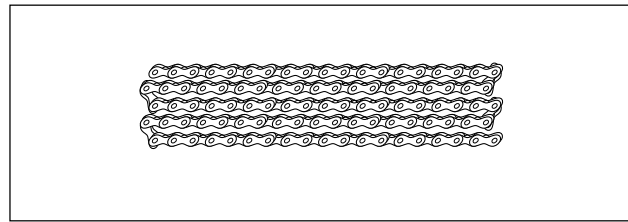

PNR.780-6230 EC-1200/1600 Chain
PNR.781-5570 EC-3600/3700 Chain
unit: pieces

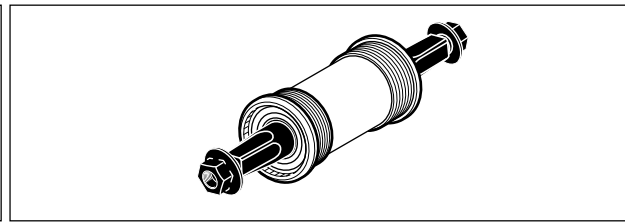

PNR.781-9200 Cartridge BB (YST-986A)
unit: sets

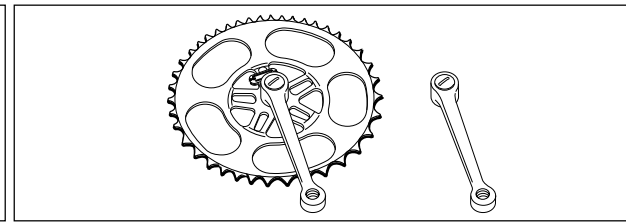

PNR.780-6250 Crank Set
unit: sets

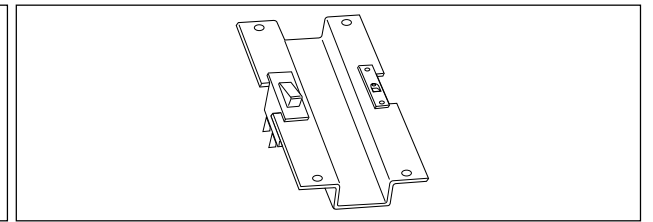

PNR.780-6240 EC-1200/1600 Inlet Metal Base
unit: sets

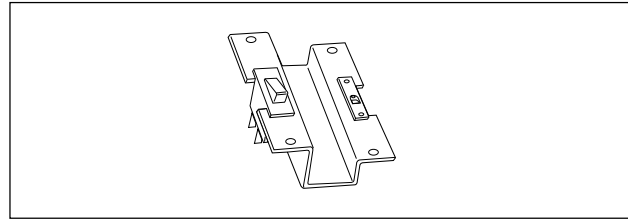

PNR.780-6241 EC-3600/3700 Inlet Metal Base
unit: sets

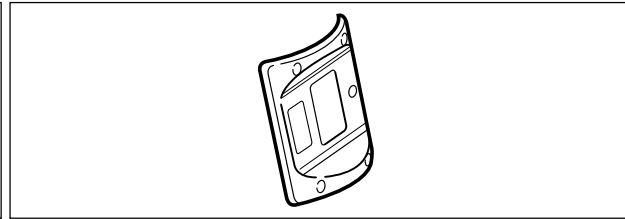

PNR.780-6030 EC-1200/1600 Inlet Cover
unit: sets

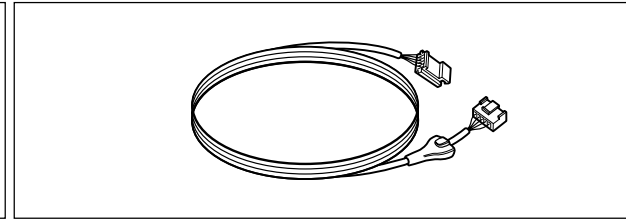

PNR.780-6220 EC-1200 5PCable
unit: sets

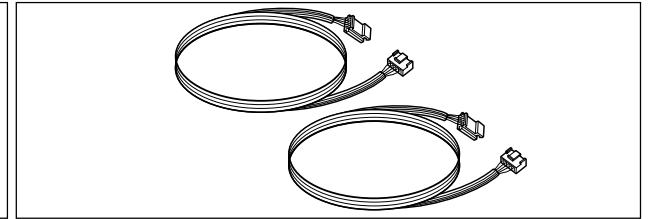

PNR.780-6480 EC-1600 5PCable (Upper)
PNR.780-6481 EC-1600 5PCable (Lower)
unit: sets

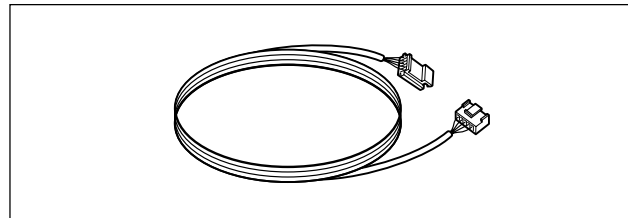

PNR.781-5550 EC-3600/3700 5PCable
unit: sets

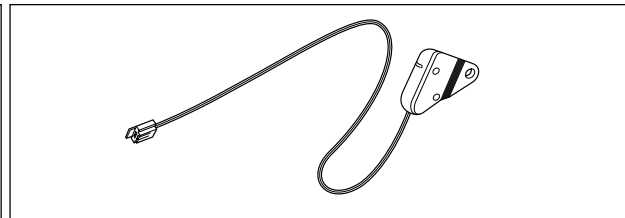

PNR.780-6241 CDC Sensor Set
unit: sets

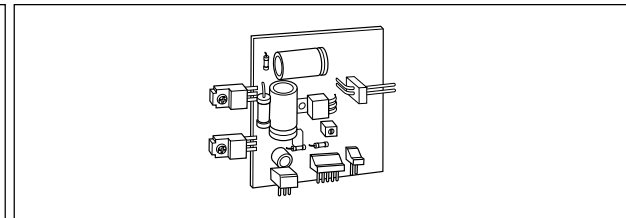

PNR.780-6210 Power Supply Board
unit: sets

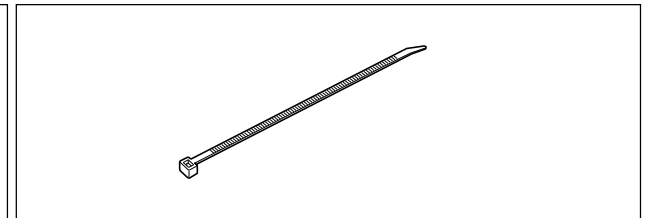

PNR.729-5010 Cable Clip Small(CV200)
unit: pieces

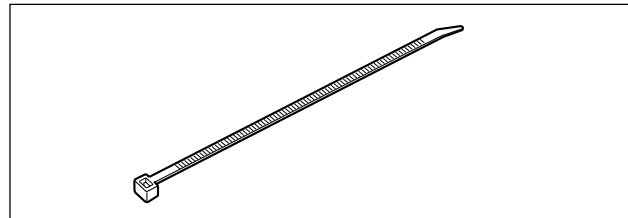

PNR.729-5025 Cable Clip Large(CV250)
unit: pieces

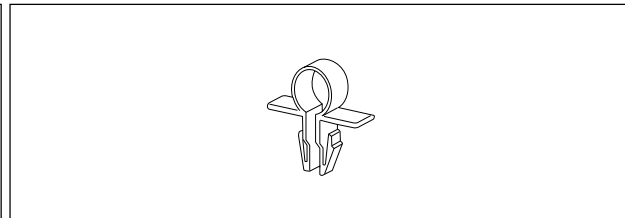

PNR.718-5140 EC-1200 Cable Holder
unit: pieces

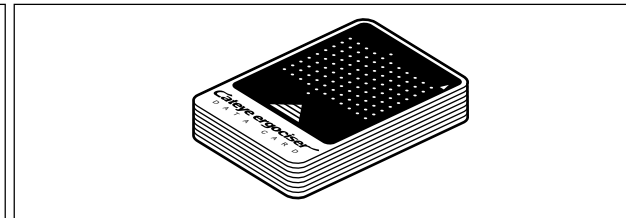

PNR.722-4950 Date Card
unit: sets

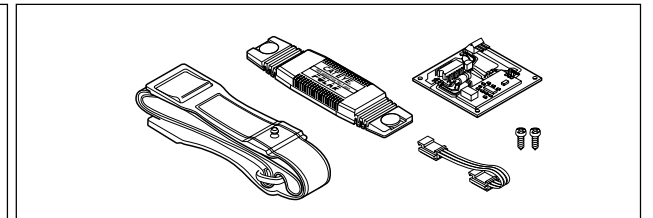

PNR.701-6701 Wireless Heart Rate Sensor Kit (TM-1000)
unit: sets

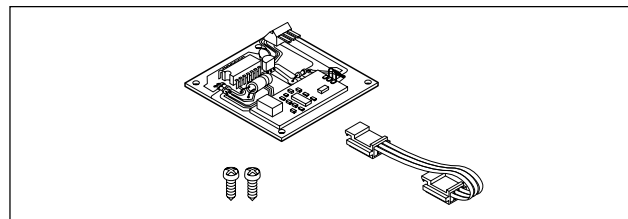

PNR.701-6801 Wireless Heart Rate Receiving Circuit
unit: sets

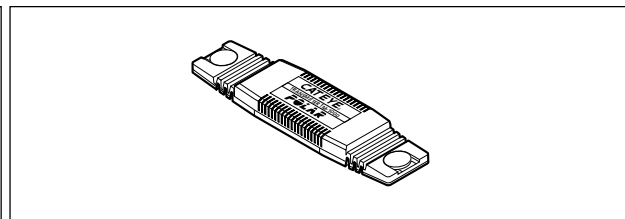

PNR.000-0000 Wireless Heart Rate Sensor
unit: sets

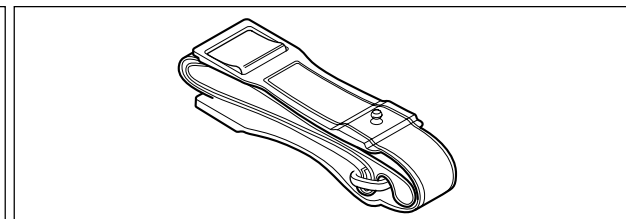

PNR.000-0000 HR Sensor Belt
unit: sets

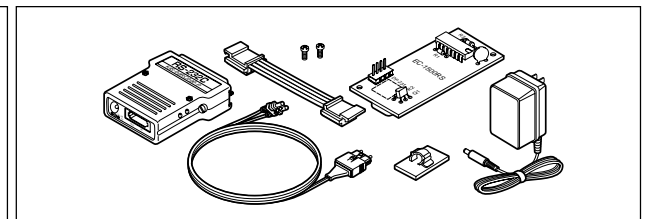

PNR.701-5701 RS232C Communication Kit
PNR.701-5703 RS232C Communication Kit (220V)
unit: sets

Belt Drive

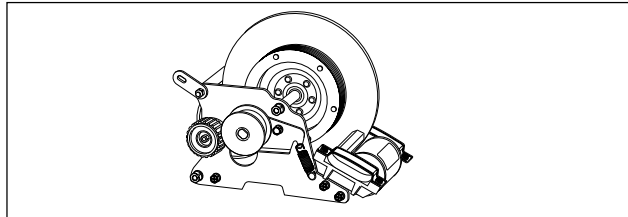

PNR.780-7050 EC-1600B/1200B Workload Unit
 PNR.781-5581 EC-3700B/3600B Workload Unit
 unit: pieces

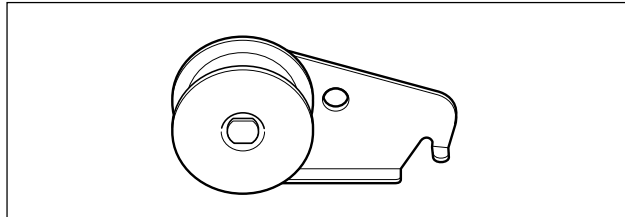

PNR.780-7030 Idler A Set
 unit: sets

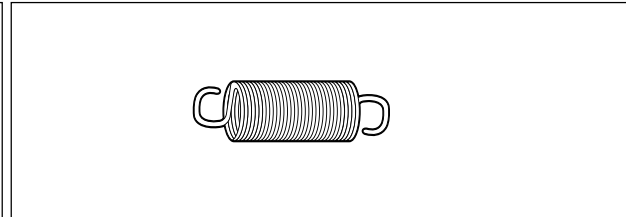

PNR.780-7040 Idler Spring A
 unit: pieces

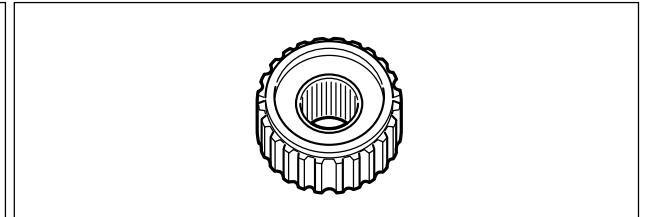

PNR.780-7010 Pulley 1-B
 unit: pieces

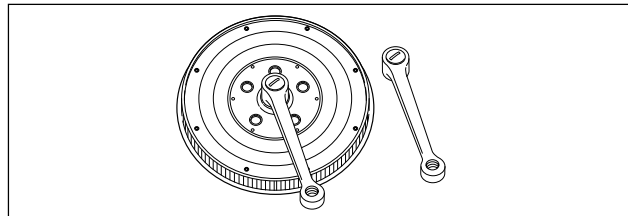

PNR.780-6990 Pulley 1-A Set
 unit: sets

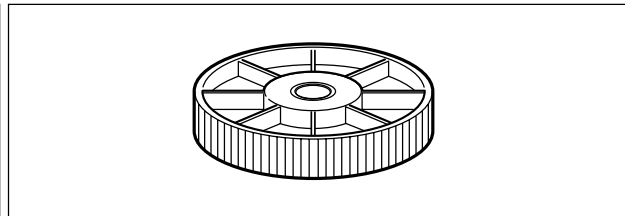

PNR.780-7020 Pulley 2-A Set
 unit: sets

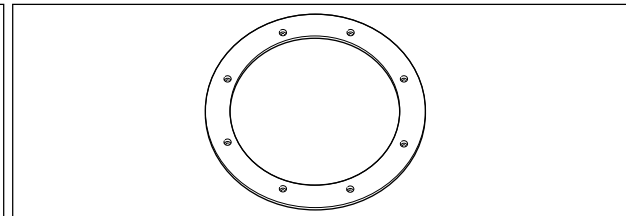

PNR.780-7000 Pulley Flange
 unit: pieces

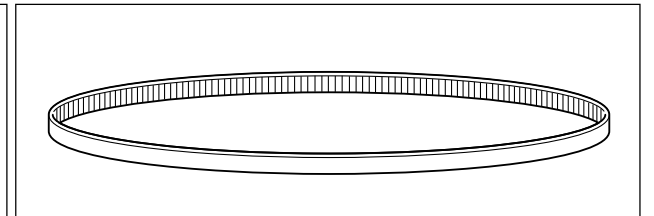

PNR.724-1021 EC-1600B/1200B Teethed Timing Belt (P8M15-1192)
 PNR.724-1022 EC-3700B/3600B Teethed Timing Belt (P8M15-1080)
 unit: pieces

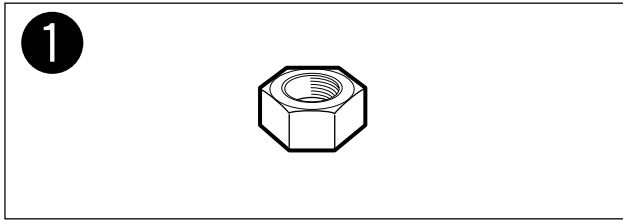

1
PNR.752-1085 Hexagon Nut M8-3
unit: pieces

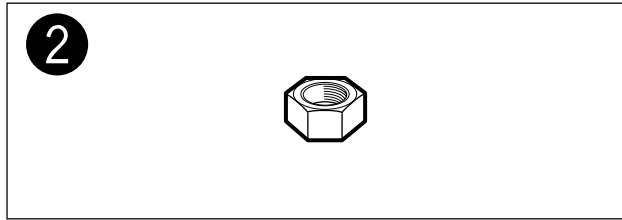

2
PNR.752-1063 Hexagon Nut M6-3
unit: pieces

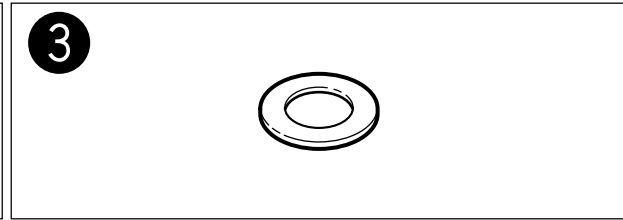

3
PNR.723-2080 Thrust Washer 9x15.5x0.25
unit: pieces

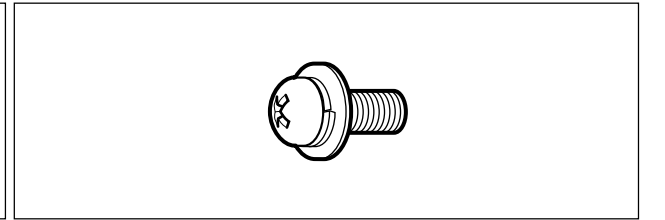

PNR.753-5410 Screw Set M6x12
unit: pieces

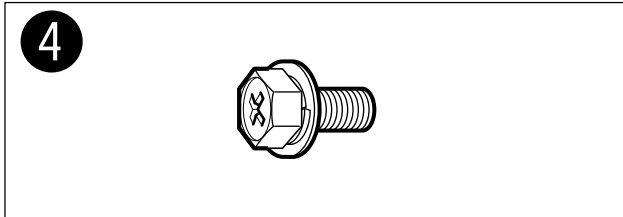

4
PNR.750-9616 Screw Set(+) M6x16
unit: pieces

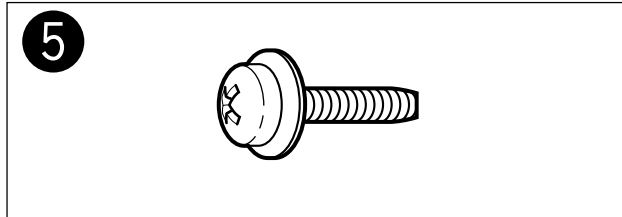

5
PNR.756-1412 Tapping Screw 4x12 with Washer
unit: pieces

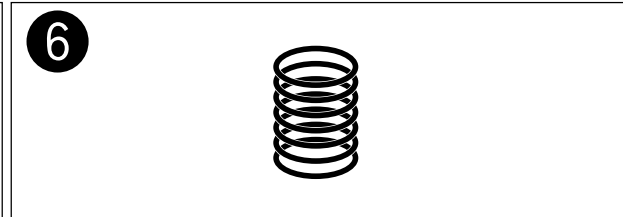

6
PNR.750-1390 Spacer Spring
unit: pieces

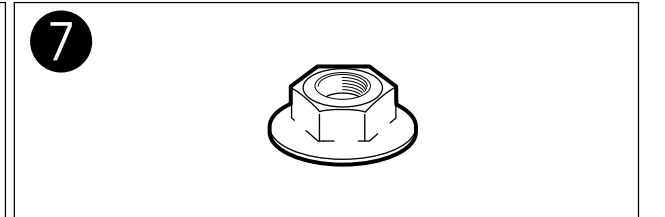

7
PNR.724-4803 Crank Nut M10x1.25
unit: pieces

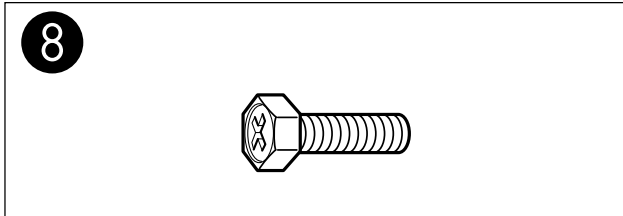

8
PNR.750-8616 Cross-recessed Head Hexagon Screw M6x16
unit: pieces

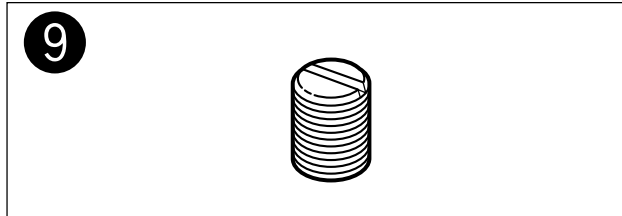

9
PNR.750-6810 Seat Post Adjust Screw M8x10
unit: pieces

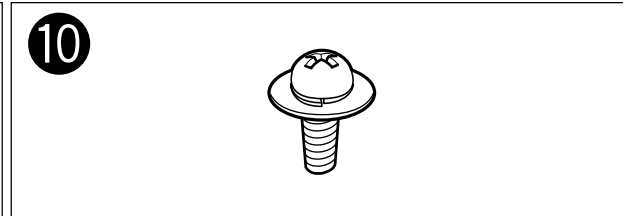

10
PNR.753-6412 Tapping Screw(2) 4x12C
unit: pieces

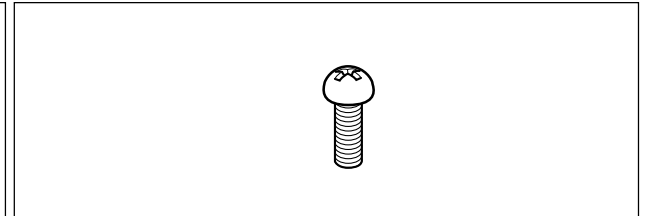

PNR.751-5330 Tapping Screw(2) 3x30
unit: pieces

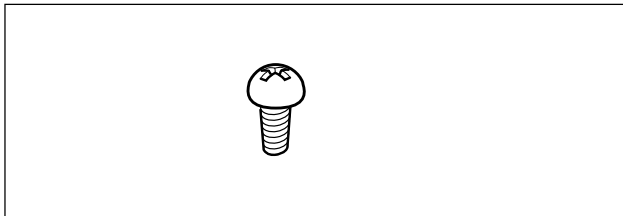

PNR.751-5208 Tapping Screw(2) 2x8
unit: pieces

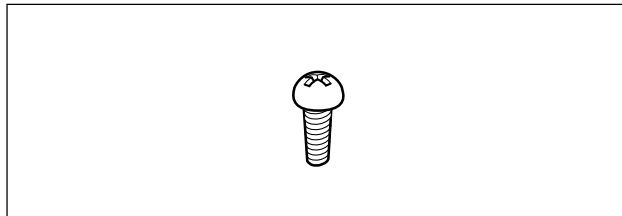

PNR.751-5206 Tapping Screw(2) 2x6
unit: pieces

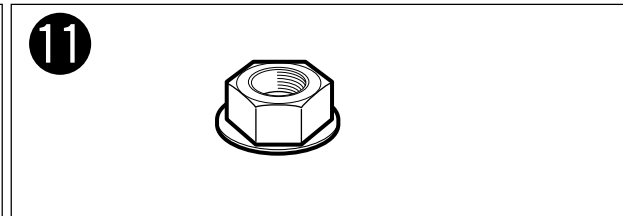

11
PNR.752-5600 SW Nut M6
unit: pieces

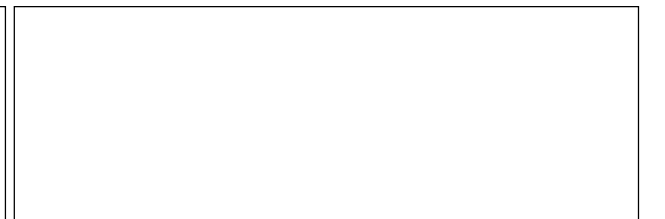
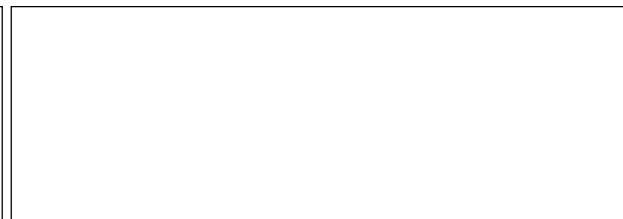
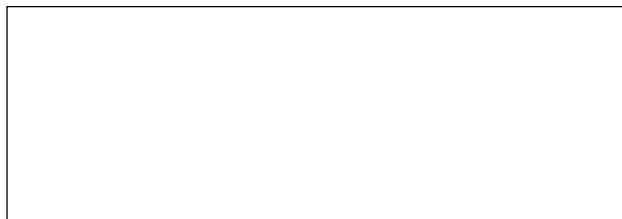
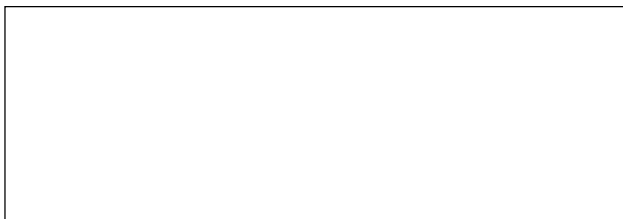
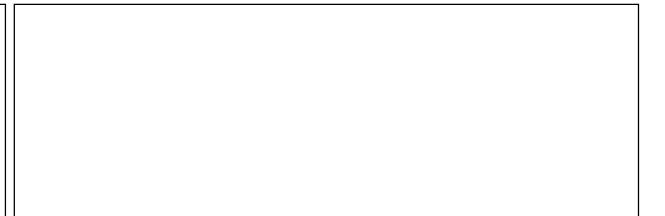

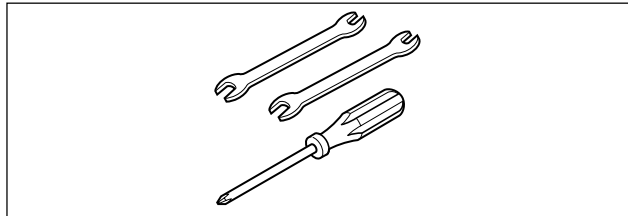

PNR.780-6350 EC-1200/1600 Tool Kit
unit: sets

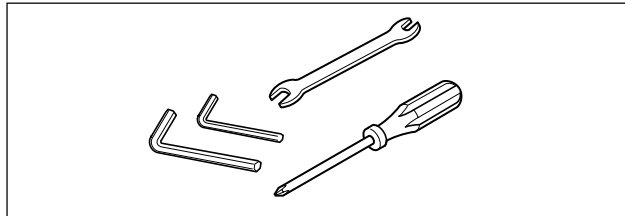

PNR.781-5180 EC-3600/3700 Tool Kit
unit: sets

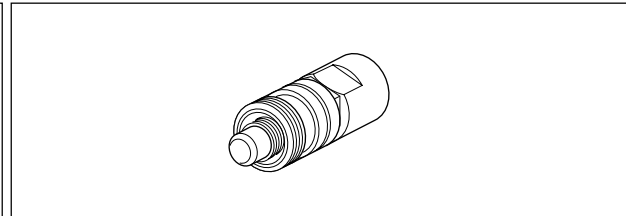

PNR.758-1000 Cotterless Gear Crank Removing /
Fastening Tool
unit: sets

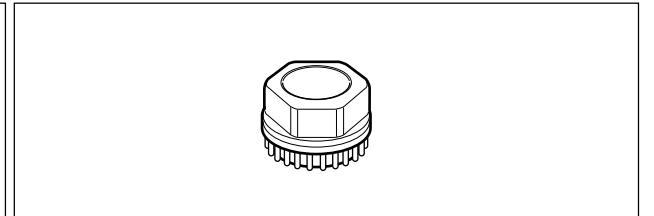

PNR.781-9210 Cartridge BB Removing Tool
unit: sets

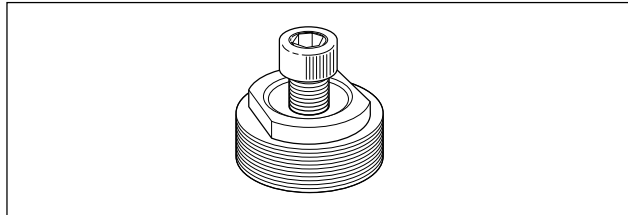

PNR.758-1010 Freewheel Set Removing Tool
unit: sets

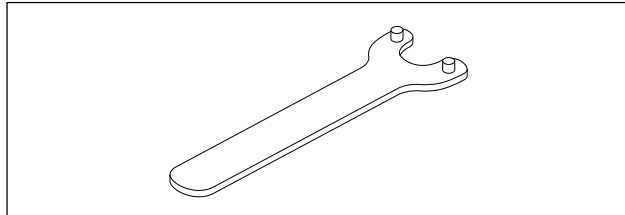

PNR.758-1080 Pin Face Wrench
unit: sets

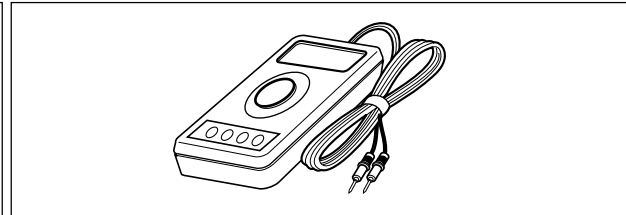

PNR.737-7000 Tester
unit: sets

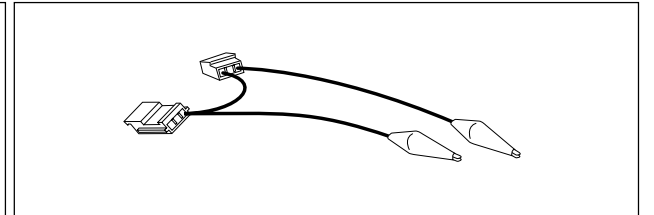

PNR.747-8000 Coil Current Measuring Cable
unit: sets

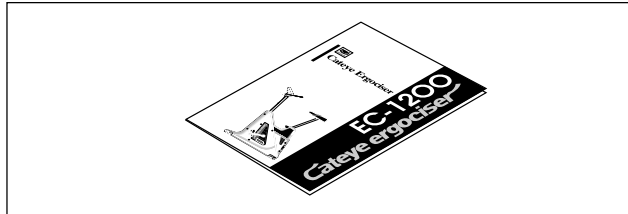

PNR.780-6111 EC-1200 Operating Instructions E
PNR.780-6112 EC-1200 Operating Instructions G
PNR.780-6113 EC-1200 Operating Instructions F
unit: sets



PNR.780-6511 EC-1600 Operating Instructions E
PNR.780-6512 EC-1600 Operating Instructions G
PNR.780-6513 EC-1600 Operating Instructions F
unit: sets

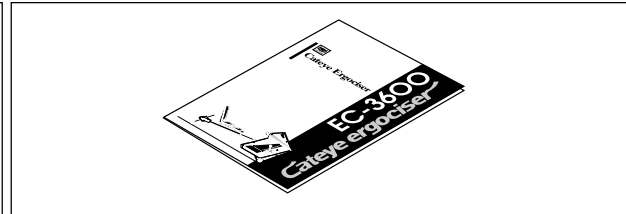

PNR.781-5701 EC-3600 Operating Instructions E
PNR.781-5702 EC-3600 Operating Instructions G
PNR.781-5703 EC-3600 Operating Instructions F
unit: sets



PNR.781-5991 EC-3700 Operating Instructions E
PNR.781-5992 EC-3700 Operating Instructions G
PNR.781-5993 EC-3700 Operating Instructions F
unit: sets

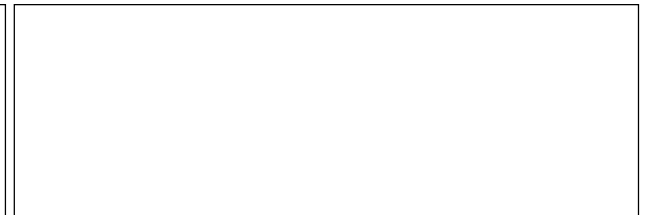
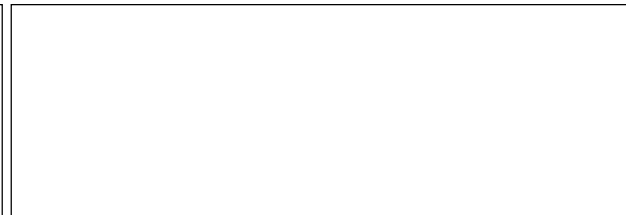
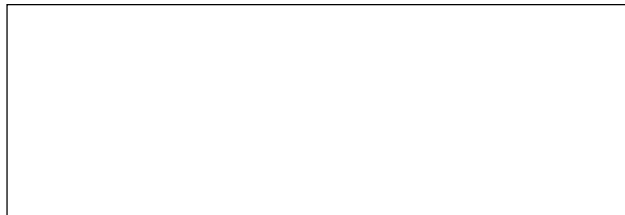
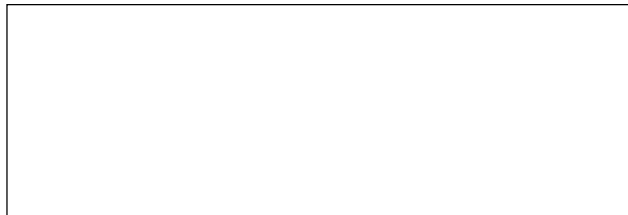
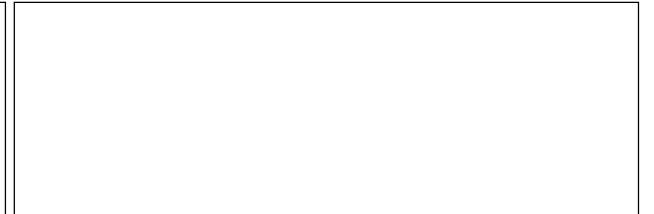
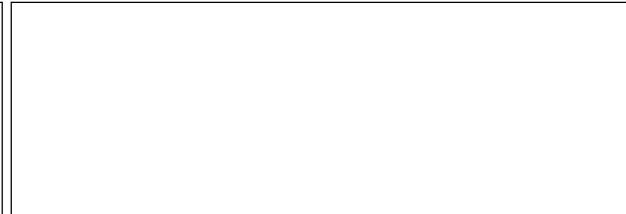
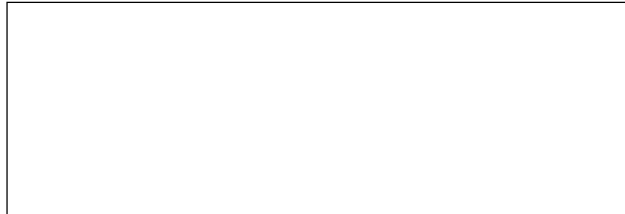
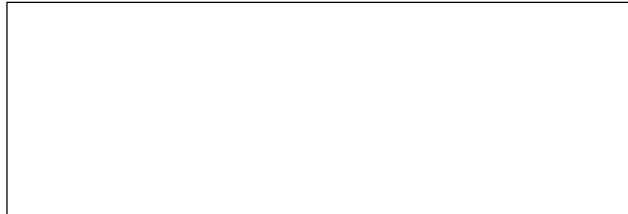



CAT EYE CO., LTD.

2-8-25, Kuwazu, Higashi Sumiyoshi-ku, OSAKA, 546-0041 JAPAN

TEL: 81-6-6719-2631 FAX: 81-6-6719-2363

Copyright © Feb. 1995 CAT EYE Co., Ltd.

ECSM1E-991007-PDF